

LIFEVIEW® QCC12

Sensor: Partial Discharge Coupling Capacitor

A partial discharge sensor suitable for machines rated 12kV and below

The LIFEVIEW® QCC12 coupling capacitor is a sensor designed to acquire high frequency partial discharge (PD) signals from motor or generator windings with only one sensor required per phase. The QCC12 sensor is designed in accordance with IEC 60270 and is fitted with a 1:1000 internal voltage divider circuit which provides a safe working voltage for any PD measuring equipment. The capacitance of the device is 1.1nF providing high sensitivity to PD signals while remaining resistant to noise sources typically found in rotating machines and electrical plant. The capacitance specified allows the device to sense PD across a large range of the rotating machine winding without the need for a second sensor on each phase.

Key Features

- 1.1nF capacitance
- For use in safe areas
- In built over-voltage protection
- Only one sensor per phase on the line terminals
- Allows for synchronised phase resolved PD pattern
- Highly sensitive sensor with minimal attenuation
- Installation kit included with QCC12 kit



Compatible With:

- LIFEVIEW PDA II
- LIFEVIEW Mobile
- LIFEVIEW Live
- Other compatible PD monitoring system

Applications:

- HV generators up to 12kV
- Industrial motors up to 12kV

#InnovativeProductsforRotatingMachines

Technical Specification

General Specifications

- Max Rated Voltage (Line to Line): 12 kV rms
- Capacitance: 1100pC @ 50Hz/20°C
Tolerance: +/-20%
- High Voltage Connection: Integrated 60cm HV cable
- Output Connection Type: 50Ω BNC
- PD-Signal: Integrated quadrupole
- Data Acquisition: According to IEC 60270 & IEC TS 60034-27
- Synchronisation Source: Integrated Voltage Divider 1:1000 (+/-20%)
- Frequency Range: 100kHz – 10MHz (0dB attenuation)
- Low cut off frequency (-3dB): 57kHz

Voltage Tests

- Withstand Voltage Test: 28kVrms 1 min
- Partial Discharge Test (<5pC): 8kVrms
- BIL test: 1.2/50µs wave 60kV peak

Environment

- Operating Temperature Range: -20°C to +85°C
- Enclosure IP Rating: IP66

Mechanical Dimensions

- Dimensions: 95mm (W) x 64mm (L) x 98mm (H)
- Weight: 0.55kg per sensor

Why QCC12?

- High sensitivity to PD signals
- Proven reliability
- Only one sensor per phase
- Compact and safe design
- Industry standard sensor for rotating

Order Code

QCC12Kit

Kit Includes:

- 3x QCC12 sensors
- QTB overvoltage protection device with earth cable
- 100m coaxial cable
- Installation kit

Technical Drawings

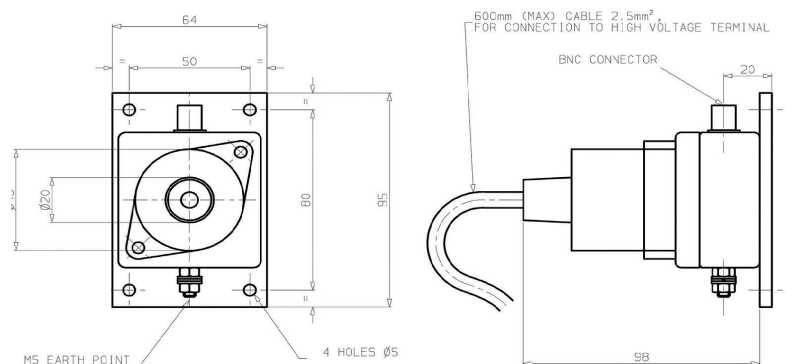

Quartzteq GmbH reserves the right, without further notice, to change the product specifications and/or the information contained in this document for improvements of the product

Key Contact Information

To request a quotation or further information please contact

Quartzteq

T: +41 (0) 56 560 20 60

info@quartzteq.com

Quartzelec

T: +44 (0)1788 512512

info@quartzelec.com

Contact Your Local Authorised Distributor

www.quartzteq.com/contact



T: +41(0) 56 560 20 60 | E: info@quartzteq.com | www.quartzteq.com