

LIFEVIEW® QCC17

Sensor: Partial Discharge Coupling Capacitor

A partial discharge sensor suitable for machines rated up to 17kV

The LIFEVIEW® QCC17 coupling capacitor is a sensor designed to acquire high frequency partial discharge (PD) signals from motor or generator with only one sensor required per phase. The QCC17 sensor is designed in accordance with IEC 60270 and is fitted with a 1:1000 internal voltage divider circuit which provides a safe working voltage for any PD measuring equipment. The capacitance of the device is 1.3nF providing high sensitivity to PD signals while remaining resistant to noise sources typically found in rotating machines and electrical plant. The capacitance specified allows the device to sense PD across a large range of the rotating machine winding without the need for a second sensor on each phase.

Key Features

- 1.3nF capacitance
- For use in safe areas
- In built over-voltage protection
- Only one sensor per phase on the line terminals
- Allows for synchronised phase resolved PD pattern
- Highly sensitive sensor with minimal attenuation
- Installation kit included with QCC17 kit
- UL 94V-0 Flame retardant epoxy resin



Compatible With:

- LIFEVIEW PDA II
- LIFEVIEW Mobile
- LIFEVIEW Live
- Other compatible PD monitoring system

Applications:

- HV generators up to 17kV
- Industrial motors up to 17kV

#InnovativeProductsforRotatingMachines

Technical Specification

General Specifications

- Max Rated Voltage (Line to Line): 17 kV rms
- Max Rated Voltage (Phase to Ground): 10 kV rms
- Capacitance: 1300pC @ 50Hz/20°C
Tolerance: +/-10%
- High Voltage Connection: M12 caphead & high voltage connecting cable
- Ground: M6
- Output Connection Type: 50Ω BNC
- PD-Signal: Integrated quadrupole
- Data Acquisition: According to IEC 60270 & IEC 60034-27
- Synchronisation Source: Integrated Voltage Divider 1:1000 (+/-10%)
- Frequency Range: 100kHz – 500MHz (0dB attenuation)
- Low cut off frequency (-3dB): 57kHz

Voltage Tests

- Withstand Voltage Test: 38kVrms 1 min
- Partial Discharge Test: PDEV > 20kVrms/50Hz @10pC
- BIL test: 1.2/50µs wave, 95kVpk

Mounting

- Horizontal or Vertical // 4 x M6 Caphead Screws

Environment

- Operating Temperature Range: -20°C to +85°C
- Area Classification: Safe Area Only

Mechanical Dimensions

- Dimensions: 140mm (W) x 95mm (L) x 140mm (H)
- Weight: 1.4kg per sensor

Why QCC17?

- High sensitivity to PD signals
- Synchronise to HV supply
- Only one sensor required per phase
- Compact and safe design
- Industry standard sensor for rotating machine application

Order Code

QCC17 Kit includes:

- 3x QCC17 sensors
- QTB overvoltage protection device with earth cable
- 100m coaxial cable
- Installation kit

Technical Drawings

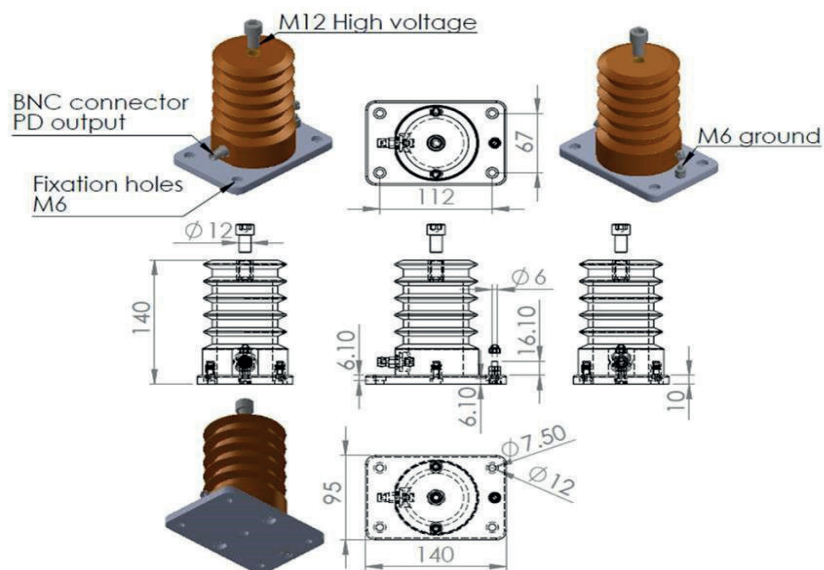

Quartzteq GmbH reserves the right, without further notice, to change the product specifications and/or the information contained in this document for improvements of the product

Key Contact Information

To request a quotation or further information please contact

Quartzteq

T: +41 (0) 56 560 20 60

info@quartzteq.com

Quartzelec

T: +44 (0)1788 512512

info@quartzelec.com

Contact Your Local Authorised Distributor

www.quartzteq.com/contact



T: +41(0) 56 560 20 60 | E: info@quartzteq.com | www.quartzteq.com