



Unparelled in Engineering Services

Low Voltage Safety Rules

Edition: 1.0
Revision: 0

1st February 2024

Issue Authority
Stephen Morrison
Managing Director
Quartzelec Ltd

www.quartzelec.com

Contents

Contents	2
Foreword	4
Purpose of These LV Safety Rules	4
Example Scenarios Illustrating where the Quartzelec HV and LV Safety Rules will apply	6
Safety Statement	8
Section 1 – General Provisions	
1.1 Legal Responsibilities	10
1.2 Organisational Responsibility	10
1.3 Specific Electrical Responsibilities	11
1.4 Training and Assessment	11
1.5 Scope and Application of The Rules	11
1.7 Variation of Safety Rules	12
1.8 Special Procedures	12
1.9 Objections	12
Section 2 – Definitions	
Section 3 – Responsibilities	
Section 4 – Planned Work Activities (Complex Work)	
Section 5 – Emergency Work or Work Under Fault Conditions	
Section 6 – Isolation	
6.1 General	27
6.2 Identification of Points of Isolation Electrical and Mechanical	27
6.3 Inspection	27
6.4 Isolating Devices	27
6.5 Securing Isolation	27
6.6 Work on a Low Voltage System Associated with a High Voltage (HV) System	28
Section 7 - Testing	
7.1 General	30
7.2 System and Apparatus Testing	30
7.3 Existing Systems and Apparatus	30
7.4 Lighting	30
7.5 Testing To Prove Dead	30
7.6 Testing Before Work Commences	30
Section 8 – Execution of the Work	
8.1 Testing and Proving Circuit Condition	32
8.2 General (Work on Dead Apparatus)	32
8.3 Working Live	32
8.4 Dangers from Arc Flash	33
8.5 Stored Energy Devices	33
Section 9 – Tests After Work	
9.1 Post Work Tests	34
9.2 Pre-Energisation Preparation	34
9.3 Post Energisation Tests	34
Section 10 – Safety Documents and Work Instructions	
10.1 General Requirements	36
10.2 HV Safety Documents for Work on LV Outgoing Circuit From a HV/LV Transformer	36
10.3 LV Permits-to-Work	36
Section 11 – Training and Authorisation	
11.1 Training and Assessment	40

Contents

11.2 Authorisation	40
11.3 Suspension / Removal of Authorisation	41
Section 12 – Arc Flash and PPE	
12.1 Introduction	42
12.2 Arc Flash Risk Assessment	42
12.3 Arc Flash Risk Levels	42
Section 13 – First Aid	
Section 14 – Non-Complex Work Guidelines	
Appendix ‘A’ – Customer Liaison Document format	48
Appendix ‘B’ – Control Transfer Certificate format.....	49
Safety Rules Procedure 1 – Live LV Working	
1 Scope	51
2 Aims and Objectives	51
3 Standards	51
4 Category ‘A’ Flow Chart.....	55
5 Category ‘A’ – Live Testing / Live Diagnostic Testing Form	56
6 Category ‘B’ Flow Chart.....	57
7 Category ‘B’ – Adding or Removing a Component Assessment Form	58
8 Live Work Certificate (Front Page).....	59
Live Work Certificate (Back Page).....	60
Safety Rules Procedure 2 – Arc Flash PPE Requirements	
1. Scope	63
2. Aims and Objectives	63
3. Arc Flash Terms	63
4. Determining an Incident Energy Value.....	64
5. Personal Protective Equipment (PPE) Requirements.....	65

Safety Statement

Foreword

These **LV** Safety Rules deal principally with electrical **Hazards**. It is accepted that for a safe system of work it should also include Risk Assessments to identify non-electrical hazards, identify control measures and how they are to be implemented.

Situations will also arise when working on Third Party networks or **Systems**, these **LV** Safety Rules will need to interface with Third Party's Safety Rules.

For clarity a number of possible scenarios that could be encountered are identified. These scenarios are not meant to be a definitive list and undoubtedly other scenarios could be encountered.

The overriding consideration must be clarity of the responsibility boundaries between whichever parties are involved and conformance with whichever Safety System or Rules apply.

Purpose of These LV Safety Rules

These **LV** Safety Rules identify the measures to be taken to comply with the duties placed on the **Company** under the relevant statutory provisions with regard to the inherent electrical **Dangers** from **LV** electricity **Systems**.

All work on electrical **Systems** is covered by the provisions of the Electricity at Work Regulations. Work on **LV Systems** downstream of the meter **Shall** be carried out with reference and in compliance to IET Wiring Regulations and any other relevant legal requirements e.g. Confined Spaces Regulations, Hazardous Substances, etc.

However, all work from the meter and upstream, namely the Network Operator's distribution system is excluded from the IET Wiring Regulations. Such Systems are covered by the Electricity Safety Quality and Continuity Regulations (ESQC Regs.) and the Electricity at Work Regulations 1989. The provisions of the Quartzelec **LV** Safety Rules are not applicable where the work is:

- On **LV Systems** upstream of the **DNO** or IDNO point of supply
- Supply Business Metering installations (not Sub-metering)
- A **Customer's System** where they have their own specific Safety Rules, e.g. NHS, etc, and the contractual requirement is to work under their Safety Management System and safety rules

These **LV** Safety Rules are created for those involved in **Complex Work**. However, for **Non-Complex Work**, the **Person(s)** carrying out the work will undertake their own personal Risk Assessment to determine the appropriate safe method of work as defined in Section 14 of these Rules.

Defined Terms

Words which appear in **Bold** type in these Safety Rules are 'Defined Terms' and are listed in Section 2 – 'Definitions'.

UK Legislative and Regulatory Framework Diagram for the selection and application of Safety Management Systems for working on Low Voltage Systems

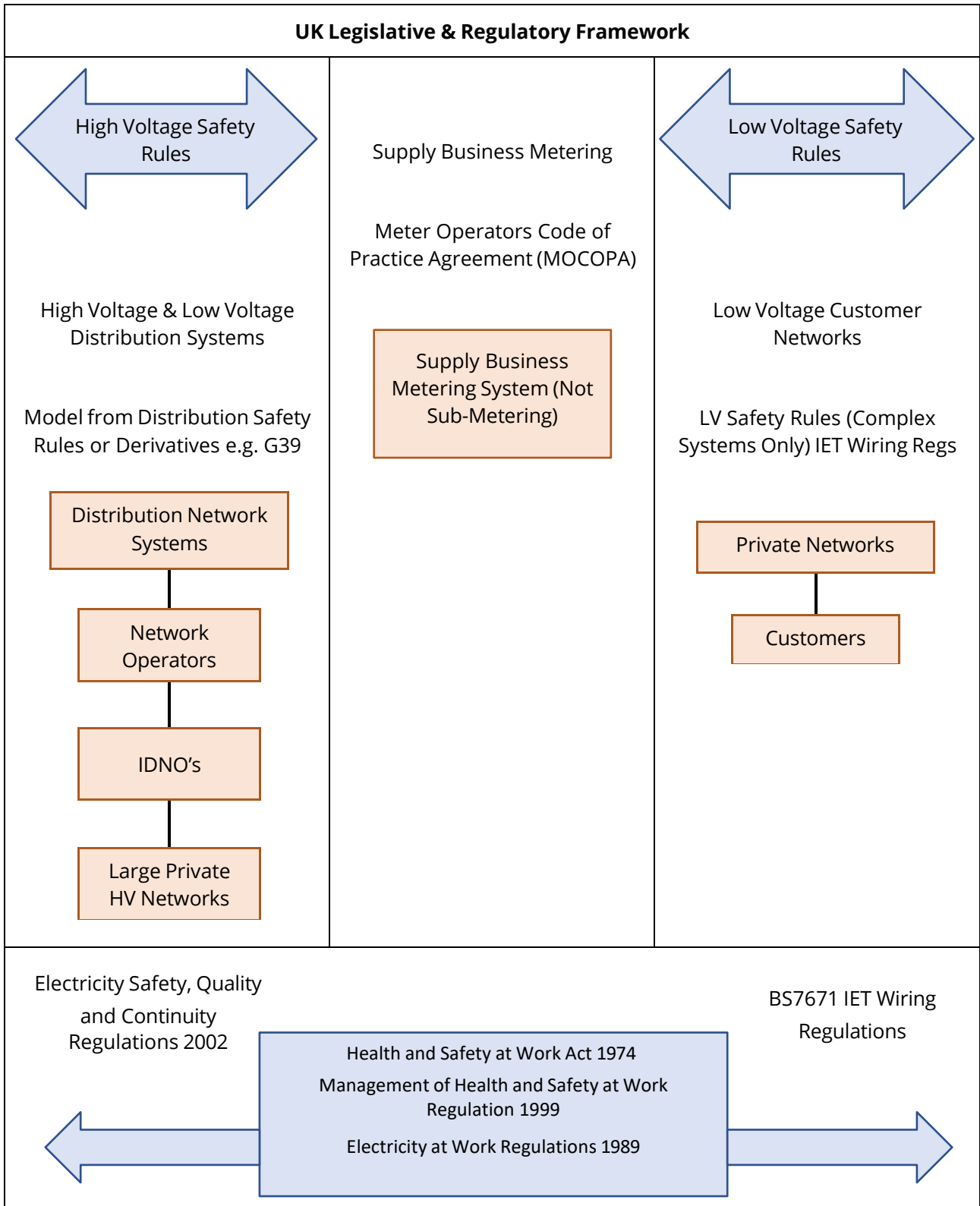

Safety Statement

Example scenarios illustrating where Quartzelec HV/LV Safety Rules will apply.

Scenario 1 - Work on LV side of HV/LV Transformer under Customer's Operational Control - HV Safety Document required please refer to HV safety rules for work at this point on the system

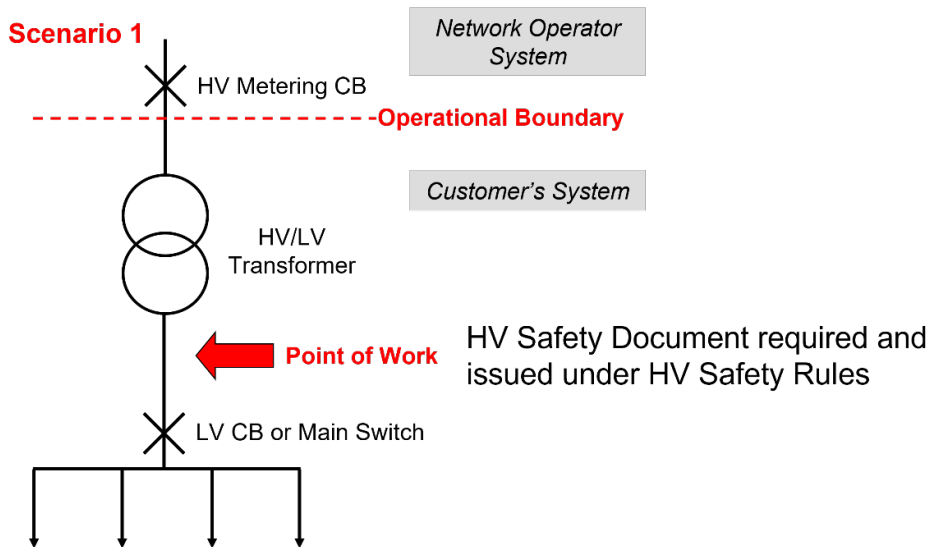

Scenario 2 - Work on LV system downstream of Transformer LV CB under DNO Operational Control - LV PTW Required

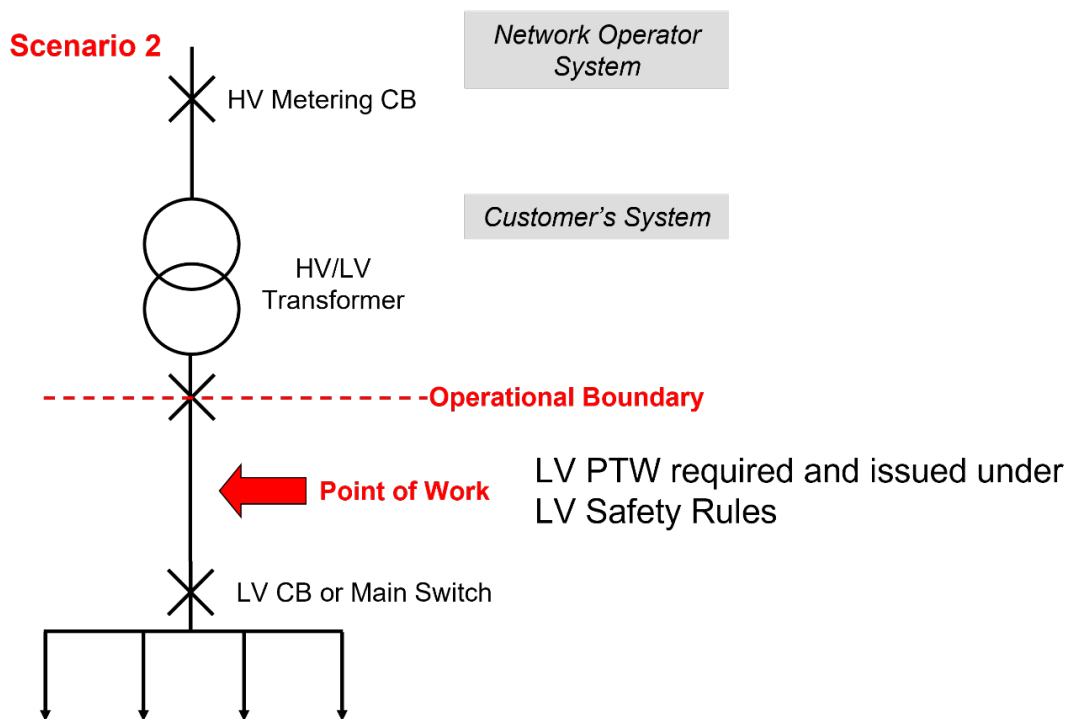

Safety Statement

Scenario 3 – Work downstream of Customer’s Main Switchboard – LV PTW if Complex Work

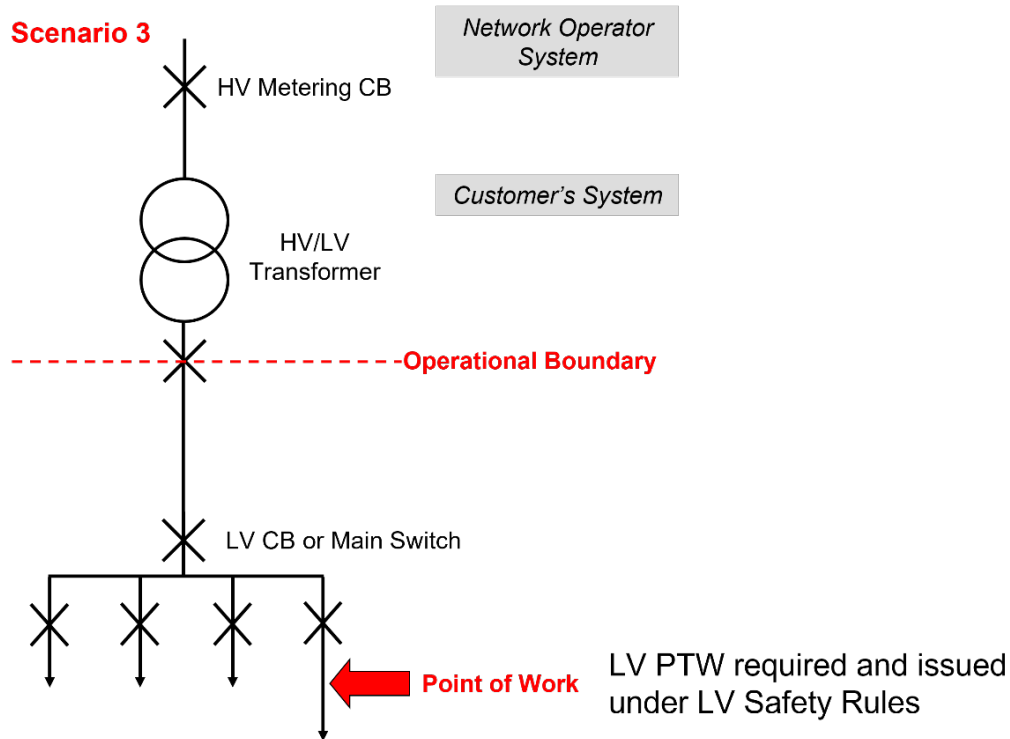

Scenario 4 – Work on LV system downstream of Customer’s main switchboard – LV PTW required if Complex Work

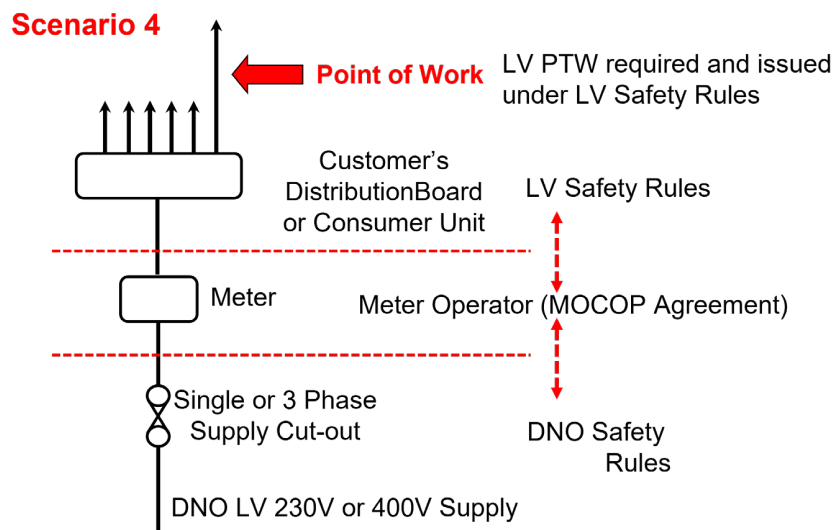

Safety Statement

Safety Statement

The **Company** has a moral and legal duty, as well as financial reasons, to protect staff and the general public from harm while the **Company's** personnel or its Contractors are undertaking work.

Moral: No one should be exposed to the risk of injury or health problems due to work.

Legal: The Law insists that employers create a safe working environment and employees work in a safe manner.

Financial: Accidents are very costly to all concerned. Safety is good business.

Important

These **LV** Safety Rules are designed to show you the correct way to carry out work safely and legally for **Complex Work**.

It is understood that a percentage of **Low Voltage** work will be undertaken with the **Systems Live**, for example, distribution network mains activity and testing of all **Systems** and equipment. Work activities carried downstream of the Network Operator's meter, should be carried out in accordance with these **LV** Safety Rules and the latest BS7671 (IET Wiring Regulations).

In addition, the majority of work on **Dead LV Systems** will be with the **Dead Conductors** unearthed. The nature of equipment and **Apparatus** used in electrical circuits where the work/testing activity falls into the category of **Complex Work**, means that frequently personnel will be working on **Dead** electrical circuits, however, the primary or adjacent equipment could still be **Live**, e.g. Form 4 / IP2X rated **LV** distribution boards.

- You will be trained in its use and the role(s) you are expected to undertake
- You will be given a written statement (your Authorisation Certificate)
- You must have access to all necessary safety equipment described in these **LV** Safety Rules

These LV safety rules are always available to access via the company website and intranet system. If printed, the printed copy is an uncontrolled copy.

Safety Statement

This page is intentionally blank

Section 1 – General Provisions

1.1 Legal Responsibilities

The Health and Safety at Work Act 1974 states.

*“It **Shall** be the duty of every employer to ensure, so far as is reasonably practical, the health, safety and welfare at work of all his employees”*

*“It **Shall** be the duty of every employee while at work to take reasonable care for the health and safety of himself and of other persons who may be affected by his acts or omissions at work”*

The **Company** recognises and accepts its moral and statutory duty to:

- Provide and enforce safe methods of working
- Provide healthy working conditions

All employees must co-operate and comply with these safety requirements and must also use the Personal Protective Equipment (PPE) provided for specific tasks.

Persons who have concerns about any instruction given or activity taking place must report their objection to their supervisor.

1.2 Organisational Responsibility

The responsibility for effective safety management in the **Company** rests with the Quartzelec Electrical Safety Management Committee. Responsibility for the execution of the safety procedures (policy writing, training, assessment and enforcement) will be delegated to named officers/positions within the management structure.

The **Company Shall:**

- a) Examine which work activities that could cause harm and carry out appropriate Risk Assessments for these activities.
- b) Provide safe working procedures that comply with the latest safety legislation.
- c) Train all staff who need to work to those procedures.
- d) Assess that those staff have sufficiently understood the procedures.
- e) Ensure that safety procedures are enforced and used by all staff.
- f) Provide all necessary Personal Protective Equipment (PPE) and the relevant instruction for its use.
- g) Review and revise the safety procedures when required.

Managers Shall:

- a) Ensure that their staff are trained and assessed for the work that they do.
- b) Ensure that the provisions of these **LV** Safety Rules are being used at all times for all **LV** work/testing activities.
- c) Only issue work instructions for Complex Work that is allowed under these LV Safety Rules and enforce the application of these LV Safety Rules at all times.

Section 1 – General Provisions

Operators/staff Shall:

- a) Work in accordance with work instructions, Risk Assessments, method statements and where appropriate, of these **LV** Safety Rules.
- b) Report any safety concerns or events to their supervisor.
- c) Always use PPE when required by these **LV** Safety Rules, Risk Assessment and Method Statement; and take care of PPE in accordance with the manufacturer's instructions.

1.3 Specific Electrical Responsibilities

- a) To achieve the requirements set out in Section 1 the **Company** have defined the following Authorisation levels for work on customers **LV Systems**.
 - **LV Competent Person**
 - **LV Authorised Person**

A definition of each category of **Person** is contained within Section 2 – Definitions

1.4 Training and Assessment

The following provisions **Shall** apply:

- a) Staff **Shall** be trained in the duties and procedures they are required to work to.
- b) Staff **Shall** be assessed, by an **Assessing Officer** to ensure they have the correct knowledge, competence and attitude for the work to be done.
- c) The **Assessing Officer Shall** recommend successful candidates to the **Authorising Engineer** for authorisation.
- d) A written authorisation certificate **Shall** be issued to each **Person** clearly outlining what they are authorised to do.
- e) All staff with authorisation certificates must present them for inspection upon request.
- f) A record will be retained by the **Company**.

1.5 Scope and Application of The Rules

These Rules **Shall** be applied to electricity generation and distribution **Systems** up to and including 1000V AC or 1500V DC and to associated **Apparatus** which are being constructed, operated or worked on by the **Company**.

The Rules **Shall** not be applied to any of the following:

- Vehicle systems
- Control and instrumentation systems
- IT equipment

These systems **Shall** be worked on using other appropriate rule sets.

Section 1 – General Provisions

1.6 Issue of Safety Rules

A copy of these Safety Rules **Shall** be available to such employees and other such **Persons** as determined by the **Authorising Engineer**.

1.7 Variation of Safety Rules

In exceptional or special circumstances these Safety Rules may be varied to such an extent as is necessary and **Approved** by the **Authorising Engineer**.

1.8 Special Procedures

Where situations exist where work or testing on **Apparatus** and **Conductors** to which these Safety Rules cannot be applied, or for special reasons should not be applied, it **Shall** be carried out in accordance with an **Approved** Safe System of Work. Such a procedure **Shall** ensure that the safety requirements of these Rules are achieved in some other way.

1.9 Objections

When any **Person** receives instructions regarding the operation of or work or testing on an electrical **System**, they **Shall** report any objections on safety grounds to carrying them out to the Person issuing them, who **Shall** have the matter investigated and, if necessary, referred to a higher authority for a decision before proceeding.

Section 1 – General Provisions

This page is intentionally blank

Section 2 – Definitions

The following definitions are the defined terms that are used in these **LV** Safety Rules.

- D1. AC** – Alternating Current – An electric current that reverses direction in a circuit at a specified or varied frequency.
- D2. APPARATUS** – All equipment in which electrical **Conductors** are used, or supported, or of which they form a part.
- D3. APPROVED** – Sanctioned for use by the **Authorising Engineer**.
- D4. ARC FLASH** – An electrical breakdown of the resistance of air and/or other insulating medium resulting in an electric arc which can occur where there is sufficient voltage in an electrical **System** and a path to earth or adjacent phase **Conductors**, or lower voltage to sustain a continuous fault current. An **Arc Flash** will cause substantial damage, fire or injury.
- D5. ASSESSING OFFICER** – A **Person** with appropriate knowledge, skill and competence to assess and recommend **Persons** to be authorised under the provisions of these **LV** Safety Rules.
- D6. AUTHORISING ENGINEER** – The engineer appointed by the **Company** to be responsible for:
- the maintenance and application of these Safety Rules in order to ensure that they are in keeping with **Company** policy and relevant legal requirements.
 - formally authorising **Persons** to undertake work/testing in accordance with these **LV** Safety Rules.
- D7. COMPANY** – Quartzelec Ltd.
- D8. COMPLEX WORK** – Where work/testing is to be undertaken on **LV Apparatus** where:
- There are multiple working parties involved
 - There are multiple locations for the same **System**
 - There are multiple means of isolation
 - There are multiple energy sources
 - Additional **Arc Flash** protection is required
 - The **Authorised Person (LV)** or **Competent Person (LV)** decides that the work is complex
 - As identified within the provisions of Section 4 of these **LV** Safety Rules
- D9. CONDUCTOR** – An electrical conductor connected to a **System**.
- D10. CUSTOMER** – The Company or organisation owning or responsible for the **System** and the **Apparatus** that is to be worked on.
- D11. CUSTOMER'S AUTHORISED PERSON** – A person who is nominated by the **Customer** to be responsible for operating/managing the **Customer's System** equipment including the operation of **HV** and/or **LV** switchgear.
- D12. CUSTOMER LIAISON DOCUMENT** – A document, used normally at the pre-work planning stage, to confirm in conjunction with the **Customer**:
- The work to be done
 - Who will control the Danger – **Customer's Authorised Person, Senior Authorised Person (HV), Authorised Person (HV)** or **Authorised Person (LV)**
 - Authorisation, where required, to operate **Customer's LV** and, where appropriate, **HV** switchgear
- D13. CUSTOMER HV SYSTEM - CONTROL TRANSFER CERTIFICATE** – a certificate which facilitates the transfer of HV System Control from the Customer to Quartzelec Ltd.
- D14. DANGER** – A risk to health, or of bodily injury.
- D15. DC** – Direct Current – An electric current flowing in one direction only.

Section 2 – Definitions

- D16. DEAD** – At or about, zero volts and disconnected from any **Live System**.
- D17. DISTRIBUTION NETWORK OPERATOR (DNO)** – The Company responsible for the operation of the local distribution network providing the electricity supply to the **Customer's** premises.
- D18. HAZARD** – A potential source of **Danger**.
- D19. HIGH VOLTAGE SAFETY MANAGEMENT SYSTEM** – Safety Rules and associated Approved Procedures / Safety Instructions, specifying the safety procedures for operating and working on **High Voltage Systems** of an equivalent standard to the current edition of the Energy Networks Association (ENA) Model Distribution Safety Rules.
- D20. INCIDENT ENERGY** – The amount of thermal energy impressed on a surface, a certain distance from the source, generated during an electrical arc event, and is typically expressed in calories per square centimetre (cal/cm²), or joules per square centimetre.
- D21. INGRESS PROTECTION** – The protection of enclosures against ingress of dirt or against the ingress of water. Conversely, an enclosure which protects equipment against ingress of particles will also protect a person from potential **Hazards** within that enclosure.
- D22. ISOLATED** – Disconnected from any **Live System** by an **Isolating Device** in the OFF position, or the removal of links all of which must establish a sufficient physical gap to prevent re-energisation. A **Caution Notice Shall** be fitted and, where possible, the device must be locked.
- D23. ISOLATING DEVICE** – A device for rendering **Apparatus Isolated**, e.g. fuses, miniature circuit breakers (MCB's), moulded case circuit breakers (MCCB's), switches.
- D24. KEY SAFE** – A device for the secure retention of keys securing points of isolation.
- D25. LIVE** – Electrically charged.
- D26. LIVE WORKING** – Work on or near **Conductors** that are accessible and **Live** or could become 'charged'.
- D27. MOCOPA** – Meter Operators Code of Practice Agreement, which outlines the principles of working on tariff metering equipment at the interface between the incoming Network Operator's point of supply and the **Customer's System**.
- D28. NON-COMPLEX WORK** – Work on **LV Apparatus** which normally requires only one point of isolation from known voltage sources and the **Arc Flash** risk is deemed to be low to ensure safety at the point-of-work.
- D29. NOTICES** – Being one of the following:
- a) **CAUTION NOTICE** – A notice fixed at a point of isolation warning against interference with the Apparatus concerned.
 - b) **DANGER NOTICE** – A notice fixed at the limit of a **Danger** zone.
- D30. PERSONS** – Being one of the following:
- a) **SENIOR AUTHORISED PERSON (HV)** – A **Competent Person** who has been appointed in writing by the **Company** to carry out specific duties, including the issue and cancellation of **Safety Documents**, i.e. **Permit-to-Work**, etc. to themselves and others.
 - b) **AUTHORISED PERSON (LV)** – A **Competent Person (LV)** who has been appointed in writing by the **Company** to carry out detailed pre-work Risk Assessments and the issue of **LV Permits-to-Work** and Risk Assessing and sanctioning **Live Working** activities including the issue of **Live Work Certificates** and assuming the role of **Person-in-Charge**.

Section 2 – Definitions

- c) **COMPETENT PERSON (LV)** – A **Person** who has been appointed in writing by the **Company** and who possesses sufficient technical knowledge, relevant practical skills and experience for the nature of the electrical work to be undertaken and is able at all times to prevent **Danger** and, where appropriate, avoid injury to themselves and others. The authorisation may include the authority to receive **Permits-to-Work (LV)**.
- d) **INSTRUCTED PERSON (LV)** – A **Person** under the **Supervision** of an **Authorised Person** or **Competent Person** to enable them to avoid electrical **Danger**.
- e) **ACCOMPANYING SAFETY PERSON** – A **Person**, with a minimum authorisation level of **Competent Person**, who is first aid trained to assist an **Authorised Person** or **Competent Person** in the event of an accident or to ensure the workspace is kept clear and unauthorised persons are prohibited. The **Accompanying Safety Person** must not become involved in the work activity and must only observe unless there is an emergency.
- f) **PERSON-IN-CHARGE** – An **LV Authorised Person**, authorised to prepare, issue and cancel **Live Work Certificates** for **Live Working** activities in accordance with **Safety Rules Procedure 1**, and take charge of the **Working Party**.

D31. PRIMARY EARTH – Earthing equipment of an **Approved** type applied before the issue of, and at a position recorded in a **Safety Document**.

D32. SAFETY DOCUMENTS – Being one of the following:

- a) **HV Permit-to-Work** – A **Safety Document** specifying the **HV/LV Apparatus** which has been made safe to work on and the work which is to be carried out.
- b) **LV Permit-to-Work** – A **Safety Document** specifying the **LV Apparatus** which has been made safe to work on and the work which is to be carried out.
- c) **Live Work Certificate** – A **Safety Document** permitting work or testing to be carried out on **Live LV Apparatus**.

D33. SAFETY LOCK – A padlock having a unique key, used to secure a point of isolation.

D34. SHALL – Where '**Shall**' is used in these Rules this indicates a mandatory requirement with no discretion permitted and no judgement to be made.

D35. SHALL, WHERE PRACTICABLE – Where '**Shall**' is qualified by the word 'practicable', a slightly less strict standard is imposed. But if the requirement is technically possible it **Shall** be met.

Example: If a switch used for Isolation has the facility to be locked, it **Shall** be locked and labelled accordingly. If no locking facility exists, then work **Shall** not commence until other suitable precautions against accidental re-energisation have been made.

D36. SIGNIFICANT ARC FLASH RISK – Where the **Incident Energy** value at the point of work exceeds 1.2 calories/cm² and could result in a Person receiving at least superficial or partial thickness burns if not equipped with suitable Arc Flash PPE. (Reference source: NFPA70E [National Fire Protection Association] – A US internationally recognised standard).

D37. SUPERVISION – Being one of the following:

- a) **IMMEDIATE SUPERVISION** – **Supervision** by a **Person** who is continually available at the location where work or testing is in progress and who attends the work area as is necessary for the safe performance of the work or testing.

Section 2 – Definitions

- b) **PERSONAL SUPERVISION – Supervision** by an **Authorised Person (HV)** and/or **Authorised Person (LV)** who is at all times during the course of the work or testing in the presence of the **Instructed Person** being **supervised**.
- D38. SUBSTATION** – A room or enclosure where electrical energy is controlled or transformed normally at a voltage exceeding 1000 volts a.c.
- D39. SWITCHROOM** – A room or enclosure area containing switchgear and/or equipment used for controlling electrical energy associated with a **System**.
- D40. SWITCHBOARD** – An assembly of switchgear with or without instruments (the term does not apply to groups of local switches in final circuits e.g. multi-ganged light control panels).
- D41. SWITCHING** – The operation of circuit breakers, switches, isolators, fuses or other methods of making or breaking an electrical circuit.
- D42. SYSTEM** – An electrical **System** constructed and operated for the supply/distribution of electrical energy and consisting of a single source or multiple sources.
- D43. SYSTEM CATEGORY** – Being one of the following:
- FINAL CIRCUIT** – A circuit connected directly to current using equipment, or to a socket outlet or other outlet points for the connection of such equipment.
 - CENTRAL POWER SUPPLY SYSTEM** – A **System** supplying the required emergency power to essential safety equipment.
 - ELECTRICAL CIRCUIT FOR SAFETY SERVICES** – An electrical circuit intended to be used as part of an electrical supply **System** for safe services.
- D44. TESTING** – Implementation of measures to assess an electrical installation by means of which its effectiveness is proved. This includes ascertaining values by means of appropriate measuring instruments, where measured values are not detectable by inspection (as per BS7671). Only **Approved** equipment should be used.
- D45. VERBAL INSTRUCTION** – An instruction or request given by the **Customer’s Authorised Person** to:
- An **LV Authorised Person** for **Complex Work**,
- or
- A **Competent Person** for **Non-Complex Work**
- that has a relevance to the safe progress of work.
- D46. WORKING PARTY** – Either persons under the **Immediate Supervision** or **Personal Supervision** of an **Authorised Person (LV)** (who **Shall** themselves be a member of the **Working Party**) or a **Competent Person** (when working by themselves).
- D47. VOLTAGES** – Being one of the following:
- EXTRA LOW VOLTAGE (ELV)** – Below 50 volts a.c. and 120 volts (ripple free) d.c. (values measured between conductors or to earth).
 - LOW VOLTAGE (LV)** – From 50 volts up to and including 1000 volts a.c. between phases and from 120 volts up to and including 1500 volts d.c. (values measured between conductors or to earth).
 - HIGH VOLTAGE (HV)** – Exceeding 1000 volts a.c. between phases and exceeding 1500 volts d.c. (values measured between **conductors** or to earth).

Section 2 – Definitions

This page is intentionally blank

Section 3 – Responsibilities

- 3.1 It is the duty of all **Persons** who may be concerned with the control, operation, work or testing, on or in the near vicinity of **Apparatus** on **Complex (LV) Systems** to which these **LV Safety Rules** apply, to implement the requirements of these **LV Safety Rules** and to comply with them. Ignorance of the relevant legal requirements, Safety Rules, Codes or Procedures **Shall** not be accepted as an excuse for neglect of duty.
- 3.2 Guidance for work/testing activities on **LV Non-Complex Systems** are detailed in Section 14 of these **LV Safety Rules**.
- 3.3 The responsibilities placed upon **Persons** may include all or part of those detailed in this section, depending on the role of the **Person**.
- 3.4 The following **Persons** will be authorised by the **Company** in writing, to operate under these **LV Safety Rules**:
- a) **Senior Authorised Person (HV)**
 - b) **Authorised Person (LV)**
 - c) **Competent Person (LV)**
- 3.5 The primary roles of these **Persons** will be as follows:
- a) **Senior Authorised Person (HV)** – Responsible for:
 - Establishing points of isolation and earthing at **High Voltage** where necessary for the proposed work/testing activities on the **Low Voltage** side of **HV/LV** transformer
 - Operating the **Customer's HV/LV** switchgear, where specifically authorised by the **Customer** to do so, to establish points of isolation and earthing
 - Ensuring that keys to **Safety Locks** controlling **HV** Points of isolation are under their control by means of double locking and/or the use of a **Key Safe**
 - The preparation and issue of a **HV Safety Document** for work on the **LV** side of a **HV/LV** transformer
 - b) **Authorised Person (LV)** – Responsible for:
 - Liaising with **Customer's** representative as may be necessary, prior to, during and completion of work/testing activities
 - Undertaking pre-work Risk Assessments
 - Establishing appropriate safety precautions prior to work/testing on defined **Low Voltage Apparatus**
 - Issue of **LV Permit-to-Work** for the work/testing activities
 - Risk Assessing and sanctioning proposed **Live Working** activities and completing a Category 'B' Risk Assessment form, issuing to self where required, a **Live Work Certificate** and assuming the role of **Person-in-Charge**
 - Responsible for providing appropriate **Immediate Supervision** and/or **Personal Supervision** to the **Working Party** where judged necessary, or a specific requirement of the **LV Safety Rules**

Section 3 – Responsibilities

- d) **Competent Person (LV)** – Responsible for:
 - Carrying out the defined work/testing activity in accordance with these **LV Safety Rules** and as specified on the **Safety Document**, or verbal instructions issued by an **Authorised Person (LV)**
 - Testing of installations as defined in the job specification and in Section 7 of these **LV Safety Rules**
 - e) **Instructed Person (LV)** – Responsible for carrying out work, as a member of a **Working Party**, under the **Supervision** of the **Safety Document** holder.
 - f) **Accompanying Safety Person** – A **Person**, with a minimum authorisation level of **Competent Person**, who is first aid trained to assist an **Authorised Person** or **Competent Person** in the event of an accident or to ensure the workspace is kept clear and unauthorised persons are prohibited. The **Accompanying Safety Person** must not become involved in the work activity and must only observe unless there is an emergency.
 - g) **Person-In-Charge** – An **LV Authorised Person** – Responsible for:
 - prepare, issue and cancel **Live Work Certificates** for **Live Working** activities in accordance with **Safety Rules Procedure 1**
 - take charge of the **Working Party** working under a **Live Work Certificate**
 - When acting as **Person-in-Charge**, provide **Personal Supervision** of the **Working Party** for the safe performance of the work
- 3.6 All **Persons Shall** hold a valid First Aid Certificate to a minimum standard of a one day 'Emergency First Aid at Work' course which complies with current Health and Safety (First Aid) Regulations 1981.
- 3.7 A summary of the responsibilities of the above **Persons** is shown in Table 3.

Section 3 – Responsibilities

Table 3

Category of Person	Duties and Responsibilities
<p style="text-align: center;">Senior Authorised Person (HV)</p>	<p>Main duties and responsibilities are:</p> <ol style="list-style-type: none"> 1. The capability to prepare, issue and cancel Safety Documents. 2. Establishing or verifying that High Voltage and LV points of isolation and earthing required for work on the LV side of a HV/LV transformer are complete in accordance with section 6, secure and adequate for the proposed work prior to the issue of a HV Safety Document. 3. Ensuring that keys controlling HV points of isolation are under their control by means of double locking and/or the use of a Key Safe. 4. The necessary competence to operate Customers' HV and LV switchgear, where specifically authorised by the Customer to do so, for establishing points of isolation and earthing as specified above.
<p style="text-align: center;">Authorised Person (LV)</p>	<p>Main duties and responsibilities are:</p> <ol style="list-style-type: none"> 1. Determine/confirm whether the work/testing activity is Complex or Non-Complex. If Complex, the following items Shall be satisfied. 2. Undertake a pre-work Risk Assessment. 3. Implement the requirements arising out of the pre-work Risk Assessment. 4. Where required, establishing or confirming that all LV points of isolation have been established (including any that may be required at HV) in accordance with Section 6 of these LV Safety Rules. 5. Ensuring that the safety precautions that have put in place are adequate for the work/testing to be undertaken. 6. Carry out testing activities in accordance with Section 7 and 8 of these LV Safety Rules to determine circuit state conditions, e.g. Live, Dead, phase rotation, insulation resistance, etc. 7. Where appropriate, confirming that the Apparatus to be worked on is Dead. 8. Where required by these Safety Rules, prepare and issue an LV Permit-to-Work and Live Work Certificates 9. When required to receive a Safety Document, ensuring that its content is clearly understood and unambiguous. 10. Ensure that all Persons in the Working Party have the necessary competencies for the work/testing activities to be undertaken. 11. Ensure that all members of the Working Party fully understand the nature and extent of the work or testing as defined on the Safety Document. 12. Risk Assess proposed Live Working activities, issue Live Work Certificates to self (where required) and assume the role of Person-in-Charge. 13. Ensure that all work activities are carried out in accordance with these LV Safety Rules.

Section 3 – Responsibilities

<p style="text-align: center;">Competent Person (LV)</p>	<p>Main duties and responsibilities are:</p> <ol style="list-style-type: none"> 1. As a member of a Working Party, comply with the requirements of the Safety Document. 2. Ensure that all work activities are carried out in accordance with these LV Safety Rules. 3. When in receipt of a Safety Document comply with any conditions, instructions or limits specified on the Safety Document during the course of the work/testing. 4. Sign onto a Safety Document as a member of a Working Party and comply with any conditions, instructions or limits specified on the Safety Document during the course of the work/testing.
<p style="text-align: center;">Instructed Person (LV)</p>	<p>Main duties and responsibilities are:</p> <ol style="list-style-type: none"> 1. Carry out work under the appropriate Supervision of an Authorised Person (LV) or Competent Person (LV). 2. Sign onto a Safety Document as a member of a Working Party and comply with any conditions, instructions or limits specified on the Safety Document during the course of the work/testing.
<p style="text-align: center;">Accompanying Safety Person</p>	<p>Main duties and responsibilities are:</p> <ol style="list-style-type: none"> 1. Observe the work activity, but not become directly involved, monitoring the wellbeing of the Working Party. 2. Raise the alarm if there is an accident, fire or explosion. 3. In the event of an incident where a member of the Working Party is injured, isolate the electrical supply safely, if possible, break contact between a conductor and the victim and administer emergency first aid. <p>Note: An Accompanying Safety Person Shall have a minimum authorisation level of Competent Person.</p>

Note: The duties and responsibilities of the **Assessing Officer** and **Authorising Engineer** is defined in Section 11 – Training and Authorisation.

Section 4 – Planned Work Activities (Complex Work)

- 4.1 In planning the work activity an assessment **Shall** be carried out as to the type of work (i.e., **Complex** or **Non-Complex**) in order to decide what documentation and/or verbal instructions are required for the activity. This activity is carried out by the Project Manager operating on behalf of the **Company**.
- 4.2 The potential **Danger** from **Arc Flash Shall** be Risk Assessed as part of the pre-work planning to determine what safety measures need to be established prior to and during the testing/work activities. This activity will normally be carried out in advance of the work, in order that an appropriate assessment can be undertaken, and consideration given to the safety measures necessary.
- 4.3 At contract commencement stage the following is to be determined and confirmed.
- The location and identification of the **Apparatus** to be worked on.
 - The nature of the work/testing activity.
 - The **Person** who is responsible for establishing points of isolation and other safety measures prior to work/testing.
 - Where appropriate, authorisation to operate the **Customer's** switchgear to make safe the **Apparatus** to be worked on or tested.

If for any reason the above is not completed at contract commencement stage then a **Customer Liaison Document (CLD)** is to be completed for work/testing activities and is to be completed at the pre-work planning stage.

- 4.4 An **LV Permit-to-Work Shall** be issued for the following work activities:
- Complex Work** activities.
 - On a main or sub-main **LV** Switchboard which has been established that it is NOT to a Form 4 (IP2X) standard.
 - Where the **Arc Flash** energy has been estimated to represent a **Significant Arc Flash Risk**.
 - On stand-by power supplies, e.g. standby generators, UPS, etc.
 - Whenever the **Authorised Person (LV)** or **Authorised Person (HV)** considers it necessary to ensure a Safe System of Work.
- 4.5 Where the work activity is on the **LV** side of a **HV/LV** transformer a **HV Safety Document Shall** be issued please refer to HV safety rules for work at this point on the system For work planned and work organised by third parties the following **Shall** be available:
- Complete details of the work to be carried out (including Risk Assessments and Method Statements).
 - Any necessary drawings and instructions.
 - The points of isolation identified.
 - Where appropriate, a completed **Isolation and Earthing Request** where **HV Apparatus** has been **Isolated** and earthed to allow the work to be carried out.

Section 4 – Planned Work Activities (Complex Work)

- 4.6 Where the work instructions do not contain all of the above information because of the type and size of work to be carried out, then the **Authorised Person (LV)** is responsible for obtaining the information and detail as itemised in Section 6.3.
- 4.7 Before commencing work the **Authorised Person (LV)**, or **Competent Person (LV) Shall**:
- Understand the **System** on which work is to be done.
 - Be satisfied with the condition and suitability of the **Apparatus** to be operated.
 - Have all the correct tools and equipment before starting, including such items as portable generators and lighting, specialist tools, etc.
 - Assess the conditions under which the testing/work may be carried out and any additional precautions that need to be taken to minimise any **Danger** that might arise due to **Arc Flash**.
- 4.8 If the **Person** responsible for the work has any doubts on any of the above items, or objects to the instructions given, they Shall raise them with the **Person** issuing those instructions. If the objection cannot be satisfactorily resolved, then the **Person** issuing such instructions, **Shall** refer the matter to a higher authority.

Liaison with the Customer

- 4.9 The **Authorised Person (LV)** or **Authorised Person (HV) Shall** inform the **Customer** of the intention to commence work activities.

Section 5 – Emergency Work or Work Under Fault Conditions

- 5.1 These **LV** Safety Rules are for work/testing activities on **Low Voltage Systems**. Where work or testing activities are required to be carried out on **High Voltage Apparatus** they **Shall** be carried out in accordance with the **Company's High Voltage** Safety Rules and appropriate **Approved** procedures by **Persons** authorised for such activities.
- 5.2 There will be occasions where personnel are required to work on installations that are not working for reasons that need to be first ascertained because for example there could be a fault.
- 5.3 Under these circumstances' equipment may be damaged to such an extent that operations or re-energisation could be dangerous for the operator and to people in the vicinity. Therefore, before any attempt is made to re-energise the circuit and/or equipment, the **Apparatus Shall** be fully tested and made safe.
- 5.4 This type of work can only be undertaken by appropriately 'authorised' personnel either a **Senior Authorised Person (HV)**, an or an **Authorised Person (LV)**, dependant on the type of **System** that is being worked on.
- 5.5 In these circumstances the appropriately authorised **Person Shall** direct and sanction all operational activities under these emergency conditions.
- 5.6 The **Senior Authorised Person (HV)** and/or **Authorised Person (LV) Shall** carry out a Risk Assessment to identify any **Hazards** and record them and any necessary actions to control or remove them on the appropriate **Safety Document**.
- 5.7 Initially the **Senior Authorised Person (HV),) or Authorised Person (LV) Shall** assess the condition of all operational equipment. Consideration **Shall** be given to the following items:
- Types of manufacture
 - Age
 - Standard of maintenance
 - State of repair

Testing to Prove Status

- 5.8 It will be necessary to carry out tests to prove the status of the **Apparatus** before any work or operations are carried out. Testing **Shall** be carried out under the requirements for **Live Working** conditions until the **Apparatus** is proven to be **Dead**.
- 5.9 Once the status of the **Apparatus** has been ascertained and Isolation has been achieved work may commence under normal arrangements set out in these **LV** Safety Rules.

Section 5 – Emergency Work or Work Under Fault Conditions

This page is intentionally blank

Section 6 — Isolation

6.1 General

The requirements set out in this section applies to both **Complex Work** and **Non-Complex Work**.

6.2 Identification of Points of Isolation Electrical and Mechanical

- a) All points of isolation **Shall** be positively identified and may include electrical points of isolation such as isolator, fuses, circuit breakers, mechanical points of isolation can be valves and isolators.
- b) This **Shall** be achieved by one or all of the following:
 - Simple inspection
 - Reference to **System** layout and labelling
 - **System** drawings
 - Identification tests

6.3 Inspection

Before operating an **Isolating Device**, it **Shall** be inspected for soundness. Factors which may make the **isolating device** unsafe to operate include:

- Age
- Corrosion
- Neglect
- Special or missing labels
- Lack of maintenance
- Damage

If the **Isolating Device** is suspect in any way, isolation **Shall** be achieved by using another suitable **Isolating Device** nearer the point of supply.

6.4 Isolating Devices

- a) Contactors, control circuits, computer-based switching software or electrical interlocks **Shall** not be used as a means of isolation.
- b) Downstream of the Network Operator's cut-out the use of MCB/RCBO, fuses and/or links will be the usual means of isolation.
- c) It **Shall** not be assumed that the operation of a switch, fuse or control, etc. will have opened all or any of the contacts, as cases of mechanical failure have been known to occur.
- d) The operator **Shall** confirm that the operation of an **Isolating Device** has achieved the intended operation.
- e) Confirmation **Shall** be obtained that the **Apparatus** has been successfully **Isolated** and is **Dead** by the use of an **Approved** testing instrument. The testing instrument **Shall** be proven to be functioning correctly before and after testing using an **Approved** proving unit.

6.5 Securing Isolation

- a) Points of isolation **Shall**, where practicable, be locked and/or fuses removed.
- b) A **Caution Notice Shall** be applied.

Section 6 — Isolation

- c) **Safety Lock** keys securing points of isolation **Shall** be held in safe custody, either in a **Key Safe**, the personal possession of the **Authorised Person (LV)** or any other **Approved** method.
- d) Where isolation is achieved by the removal of fuse links, or busbar links they **Shall** be held in safe custody of the **Person** responsible for work and a **Caution Notice** applied to the fuse holders to prevent the insertion of duplicate fuses.
- e) If isolation is achieved by means of an **LV Switch Fuse, Fused Switch, Switch or MCB/RCBO**, it **Shall** be secured by:
 - The application of a **Safety Lock** and **Caution Notice**
 - If it is not possible to apply a **Safety Lock**, remove fuses or links and apply a **Caution Notice** and keep the removed fuses or links in safe custody of the **Person** responsible for the work

6.6 Work on a Low Voltage System Associated with a High Voltage (HV) System

- a) When work on an **LV System** requires a **HV System** to be made **Dead, Isolated** and earthed, a **HV Safety Document** please refer to HV safety rules for work at this point on the system . The **HV Safety Document Shall** include the isolation and earthing that has been carried out on the **System** in order to make the **Apparatus** safe.
- b) Prior to the issue of a **HV Safety Document** a **Senior Authorised Person (HV)** or **Shall** ensure that all necessary points of isolation and earthing have been established, are secure and can be maintained by them throughout the course of the work/testing.
- c) **Senior Authorised Persons (HV)** undertaking switching operations on **High Voltage Systems, Shall** undertake such operations in accordance with a **High Voltage** Safety Management System which their employer has in place and which has been verified in writing by the **Company**, as being of a satisfactory standard. The **Senior Authorised Person (HV) Shall** also hold authorisation as a **Senior Authorised Person (HV)** under this **High Voltage** Safety Management System.
- d) Where a **Senior Authorised Person (HV)** requests **HV** points of isolation and earthing to be established which are under the operational control of a third party, e.g. the local **DNO** (Network Operator) or the **Customer's** appointed **Senior Authorised Person**, then such points of isolation and earthing **Shall** be established by the third party at the request of the **Company's** appointed **Senior Authorised Person (HV)** The mechanism for doing so will be by means of an **Isolation and Earthing Request (IER)**. The **IER Shall** record the **HV** points of isolation and earthing which have been carried out and will be maintained until the **Senior Authorised Person (HV)** or requests in writing, by the completion of the appropriate sections of the **IER**, that they are removed.
- e) The **Senior Authorised Person (HV) Shall** ensure that all **HV** or **LV** points of isolation established by a third party are secure, by the application of **Safety Locks** and **Caution Notices** and that all **Safety Lock** keys are placed in a **Key Safe** and a **Key Safe** key is issued to the third party **Authorised/Senior Authorised Person**. If for any reason that this is not feasible, the **Senior Authorised Person (HV) Shall** apply their own **Safety Locks** by double locking or the use of multi-lock hasps.
- f) The **Senior Authorised Person (HV)** prior to issuing the **Permit-to-Work** is responsible for verifying:

Section 6 – Isolation

- That all necessary points of isolation and earthing, both at **HV** and **LV**, have been established, are secure and are adequate for the work/testing to be carried out
 - That the **Apparatus** to be worked on or tested has been:
 - Positively identified
 - Proved to be **Dead** at the point of work by testing with an **Approved** testing device or other **Approved** means
 - Screened where necessary to prevent accidental contact with any adjacent **Live LV Conductors** in close proximity to the point of work
 - **Danger Notices** applied to adjacent **Live Apparatus** upon which work/testing is not permitted
- g) The issue and receipt of the **HV Safety Document** Shall be as follows:
- i) A **Senior Authorised Person (HV) Shall** issue a **HV Safety Document** in accordance with the **HV Safety Rules**. Alternatively, a **Senior Authorised Person (HV) Shall** issue a **HV Safety Document** to themselves and take responsibility for the **Working Party**.
 - ii) When work on any **LV System** is to be carried out and is associated with work on a **High Voltage system** for which a **HV Safety Document** has been issued, and the **LV** work can only be done while the **HV System** remains **Dead** and earthed the following will apply:
 - The **Safety Document** issued for the **LV** work **Shall** detail the **Apparatus** made safe for the work to proceed
 - Reference **Shall** be made on both **Safety Documents** to the existence of the other **Safety Document**, quoting the relevant serial number together with the use of appropriate **Key Safes**

Section 7 – Testing

7.1 General

A high proportion of **LV** testing will be undertaken under **Live** conditions. For example, it is assumed that the **Apparatus** and/or **System** is **Live** prior to proving **Dead**.

7.2 System and Apparatus Testing

When carrying out a test procedure, additional consideration **Shall** be made with regards to the inherent **Dangers** that may exist from the **System** to be tested and any adjacent **Live Conductors**.

7.3 Existing Systems and Apparatus

Following completion of work the **System** or **Apparatus** configuration should remain as found, unless it is specifically part of the work to alter.

7.4 Lighting

Sufficient lighting **Shall** be provided for the testing to be done safely. A hand-held torch is inadequate.

7.5 Testing To Prove Dead

- a) **Approved** voltage test instruments fitted with fused leads **Shall** be used to prove **LV Apparatus** is either **Live** or **Dead**. The use of test scopes, multi-meters and voltsticks are NOT acceptable as a sole means of proving **Live** or **Dead**. All test instruments **Shall** be tested immediately before and after use using an **Approved** proving unit.
- b) Where practicable proving **Dead Shall** be undertaken at the point of work.
- c) When testing to prove **Dead**, the following procedure **Shall** be applied:
 - i) Inspect at the point of work the suitability to carry out the test. If it is unsafe to test at the point of work, then the test to prove **Dead Shall** be carried out at another point on the circuit as close as possible to the intended work position. It is essential that this is completed before removing cable sheaths, covers or access plates to the circuit **Conductors** to be worked on.

Note: Some covers and plates may have labels, warning signs and instructions on them. This does not remove the need for the proving **Dead** procedure to be carried out.

- ii) The proving **Dead** tests **Shall** include tests between phases and earth, phase to phase, phases to neutral and neutral to earth to guard against the possibility of incorrect connections.

7.6 Testing Before Work Commences

- a) Before any work is carried out, the integrity of the existing **System Shall** be tested and recorded. Certain tests can only be carried out with the **Apparatus Live**, whilst other tests can only be undertaken with the **Apparatus Dead**.
- b) Prior to any work being carried out the following **Shall**, where practicable, be assessed and recorded for comparison with post-work values:
 - i) Voltage
 - ii) Phase sequence
 - iii) Polarity
 - iv) Earth loop impedance
 - v) Insulation resistance
- c) Circuit state tests (i) - (iv) will normally be undertaken with the circuit **Live**.

Circuit state test (v) will be undertaken with the circuit **Dead**.

Section 7 – Testing

This page is intentionally blank

Section 8 – Execution of the Work

8.1 Testing and Proving Circuit Condition

- a) Treat the **System** as **Live** until proven **Dead**.
- b) Proving **Dead** ensures that the **Apparatus** to be worked on is not **Live**, not electrically charged at dangerous voltages and is safe to work on.

8.2 General (Work on Dead Apparatus)

Persons carrying out work on **Dead Apparatus, Shall:**

- a) Have a clear understanding of the work to be done.
- b) Not exceed the extent of the **LV Permit-to-Work** and work beyond any defined boundaries.
- c) Ensure general safety aspects are satisfied, e.g. working at height, hazardous substances, correct PPE worn, etc.
- d) Confirm points of isolation.
- e) Inspect tools and other equipment are undamaged and fit for use.
- f) Keep the work area tidy and access/egress ways clear.
- g) Maintain a constant awareness of the need to ensure safety of yourself and others.
- h) Not interfere with safety precautions maintaining points of isolation.

8.3 Working Live

- a) **Live Working** is work on or near **Conductors** that are accessible and **Live** or electrically charged.
- b) The requirements of Regulation 14 of the Electricity at Work Regulations 1989 **Shall** be met if **Live Working** is to be carried out.

Electricity at Work Regulations - Regulation 14

No person shall be engaged in any work activity on or so near any live conductor (other than one suitably covered with insulating material so as to prevent danger) That danger may arise unless –

it is unreasonable in all the circumstances for it to be dead; and

it is reasonable in all the circumstances for him to be at work on or near it while it is live; and

suitable precautions (including where necessary the provision of suitable protective equipment) are taken to prevent injury

- c) There are many **Live LV** work/testing activities, where working **Live** may be necessary and is justified including:
 - Proving **Dead**
 - Functional Testing
 - Diagnostic Testing
 - Working on a switchboard or any **Apparatus** that has a **Live** feed or is not totally **Isolated**
 - Where there is a risk of coming into contact with **Live Conductors**

Section 9 – Tests After Work

- d) All **Live Work** activities **Shall** be carried out in accordance with **Safety Rules Procedure 1 (SRP1) - Live Working**, by **Persons** who are trained, competent and authorised by the **Company** to carryout **Live Work** activities which is limited to the following two categories:
- Category 'A' – Testing on Distribution Boards which are Form 4 / IP2X compliant
 - Category 'B' - Adding or Removing a Circuit or Switchboard Component' or Battery Work
- e) For the two above listed **Live Working** categories, an **Accompanying Safety Person Shall** be in attendance.
- f) The following **Live Working** testing activities are exempt from the requirements of **SRP1 – Live Working**, but subject to the requirements for use of **Approved** PPE and Test Equipment:
- Proving **Dead** in accordance with an **Approved testing** procedure using **Approved** GS38 compliant test equipment.
 - Functional testing to obtain readings of equipment operating values or performance, where the process will ensure there is no risk of contact with Live Conductors, connections or terminals, or the short circuiting of Conductors.
 - Non-intrusive inspection, where the process will ensure that there is no risk of contact with exposed **Conductors**, connections or terminals **Live at Low Voltage**, or the short circuiting of **Conductors**, in accordance with a Safe System of Work or Method Statement.

8.4 Dangers from Arc Flash

Where **Complex Work** activities involve working on or adjacent to **Live Apparatus** an assessment **Shall** be undertaken to establish the potential **Danger** from **Arc Flash** and in order to reduce the effects of such **Arc Flash**, PPE as identified in Section 12 **Shall** be worn by all **Persons** involved in the work activity.

8.5 Stored Energy Devices

- a) It is not uncommon to find devices in **LV Systems**, with the ability to store electrical energy. These types of devices can be:
- Capacitors
 - Uninterruptible Power Supplies (UPS)
 - Emergency lighting battery systems
- b) When **Isolated** from the **System**, it may be necessary to apply additional safety measures such as:
- Discharging and then shorting capacitors
 - Isolate battery power source, or alternately shroud exposed **Live** terminals

Section 9 – Tests After Work

9.1 Post Work Tests

Tests **Shall, Where Practicable**, be carried out in the following sequence:

- a) Continuity of protective **Conductors**, including main and supplementary bonding
- b) Continuity of circuit **Conductors**
- c) Insulation resistance
- d) Assessment of separation of circuits
- e) Assessment of barriers enclosures
- f) Labelling and circuit identification are correct

9.2 Pre-Energisation Preparation

Following satisfactory post work testing the **Customer's Authorised Person** or the **Authorised Person (LV)** or **Senior Authorised Person (HV)** responsible for controlling the **Danger** and establishing the pre-work safety measures **Shall**:

- a) Inform the appropriate personnel that the work has been completed and that all **Safety Documents** have been cancelled
- b) Check to ensure that any disconnections removed for testing have been restored
- c) Confirm with the appropriate personnel that the **System** can be energised
- d) Remove any **Caution Notices** and restore points of isolation to the position that existed prior to work
- e) Restore the **System** to service

9.3 Post Energisation Tests

The following tests **Shall, Where Practicable**, or where specifically required, be carried out:

- a) Check for correct voltages between phases and phase to neutral/earth
- b) Polarity
- c) Check phase rotation and ensure it is the same as it was before work commenced
- d) Earth electrode resistance
- e) Earth Loop Impedance

Section 9 – Tests After Work

This page is intentionally blank

Section 10 – Safety Documents

10.1 General Requirements

- a) An **LV Permit-to-Work Shall** be issued for all **Complex Work** where the **Apparatus** to be worked on is **Dead** and **Isolated** from all sources of electrical energy, except for work/testing activities outlined in paragraph 10.1.(b) below.
- b) In situations where it is necessary to establish points of isolation on a **HV System** then a **HV Safety Document Shall** be issued by a **Senior Authorised Person (HV)** in accordance with the HV Safety Rules
- c) The format of the **LV Permit-to-Work** is illustrated in Fig.10 .1.
- d) Only an **LV Authorised Person** can receive a **Verbal Instruction** for work/testing classified as **Complex Work**. In such situations the **Authorised Person** on receipt of a **Verbal Instruction Shall** record the details on the **Customer Liaison Document** and prepare an **LV Permit-to-Work** recording the appropriate information and undertaking the appropriate pre-work/testing Risk Assessments. Where the work/testing activities require the **Authorised Person (LV)** to operate the **Customer's LV** switchgear consent to operate **Shall** be recorded on the **Customer Liaison Document** and formally confirmed by the Customer's representative.
- e) For **Non-Complex Work** activities a **Competent Person (LV)** can receive a **Verbal Instruction**. In such circumstances an **LV Permit-to-Work** is not required. However, the **Competent Person (LV)** is responsible for carrying out the appropriate pre-work Risk Assessments and ensuring that the **Apparatus** to be worked on is **Dead** and **Isolated**.

10.2 HV Safety Documents for Work on LV Outgoing Circuit From a HV/LV Transformer

- a) Authority for Issue:
 - i) A **HV Safety Document Shall** be issued by a **Senior Authorised Person (HV)** before any work/testing is carried out on **Low Voltage Apparatus** or **Conductors** on the **Low Voltage (LV)** side of a **HV/LV** transformer. Where more than one **Working Party** is involved a **Safety Document Shall** be issued to the **Person** in direct charge of each **Working Party** and these **Shall**, where necessary, be cross-referenced one with another

10.3 LV Permits-to-Work

- a) Authority for Issue:
 - i) **LV Permits-to-Work Shall** be issued by:
 - An **Authorised Person (LV)** to themselves or an **LV Competent Person**
- b) Procedure for Issue and Receipt:
 - i) The **LV Permits-to-Work Shall** be explained and issued to the **Person** in direct charge of the work, who after reading its contents and confirming that he understands it and is conversant with the nature and extent of the work to be done, **Shall** sign its receipt and its duplicate. The recipient **Shall** confirm their understanding by explaining the safe working area, the work to be carried out, and precautions required. The recipient **Shall** also ensure that the **LV Permit-to-Work** is properly explained to the other members of the **Working Party** and each member of the **Working Party** signs the appropriate sections of the '**Working Party Control**' Section of the **LV Permit-to-Work**.
 - ii) The recipient of an **LV Permit-to-Work Shall** retain the **LV Permit-to-Work** in their possession at all times whilst work is being carried out.

Section 10 — Safety Documents

- iii) Where more than one **Working Party** is involved a **Safety Document Shall** be issued to the **Authorised Person** or **Competent Person (LV)** in direct charge of each **Working Party** and these **Shall**, be cross-referenced one with another.
- c) Procedure for Clearance and Cancellation:

An **LV Permit-to-Work Shall** be cleared and cancelled by the **PTW** Issuer, when work on the **Low Voltage Apparatus** or **Conductors** for which it was issued has been completed.

If more than one **LV Permit-to-Work** has been issued, then the **Person** cancelling the document **Shall** ensure that all **Safety Documents** have been cleared and cancelled before proceeding with testing or energisation of the **Apparatus**.

Fig. 10.1a LV Permit-to-Work – Front

		Low Voltage Permit-to-Work		PTW No:	
1. Identification System, Equipment and Work					
Location:					
LV System to be worked on:					
Work/Testing to be carried out:					
2. Safety Precautions before work					
State exactly the safety measures which have been implemented to remove or control Hazards to enable the work to proceed. The following safety precautions are in place:					
1.		Isolation device or Safety Lock fitted		Yes <input type="checkbox"/>	
2.		Isolation device or Safety Lock fitted		Yes <input type="checkbox"/>	
3.		Isolation device or Safety Lock fitted		Yes <input type="checkbox"/>	
4.		Isolation device or Safety Lock fitted		Yes <input type="checkbox"/>	
5.		Isolation device or Safety Lock fitted		Yes <input type="checkbox"/>	
LV system to be worked on have been proved dead at point of work?				Yes <input type="checkbox"/>	
Emergency response procedures known and understood				Yes <input type="checkbox"/>	
Correct PPE available as specified in the RAMS / Safe System of Work				Yes <input type="checkbox"/>	n/a <input type="checkbox"/>
Further precautions to be taken during the work:					
3. ISSUE:					
I confirm:					
<ol style="list-style-type: none"> 1. The safety precautions listed in Section 2 are in place and will remain in place until this Permit is cancelled. 2. The RAMS for this work have been examined and judged to be satisfactory for the specified work. 3. The Person nominated to receive this Permit and take charge of the Working Party has provided evidence of their competence to carry out this work. 					
Print Name:		Being an LV Authorised Person			
Signed:		Time:		Date:	
Mobile Number:					
4. RECEIPT:					
I understand the work to be done and accept my responsibilities under this Permit-to-Work and will not attempt to work on any other apparatus or interfere with any safety measures which have been put in place.					
Print Name:		being an LV Competent Person			
Signed:		Time:		Date:	
Mobile Number:		Employed by:			

Fig. 10.1b LV Permit-to-Work - Back

5. CLEARANCE					
I confirm that all Persons working under this Permit-to-Work have withdrawn from and warned not to work on the LV System detailed in Section 1 and that the work is complete.					
I confirm I have returned the LV PTW issued to me, back to the LV Authorised Person who has issued the PTW.					
Print Name:	Being the PTW Recipient detailed in Section 4				
Signed:		Time:		Date:	

6. CANCELLATION:					
I confirm one of the following:					
The LV System is ready to be returned to service subject to satisfactory testing.					<input type="checkbox"/> Check
The LV System is in a safe state, however, cannot be returned to service.					<input type="checkbox"/> Check
THIS PTW IS NOW CANCELLED, AND NO FURTHER WORK IS PERMITTED					
Print Name:	being an LV Authorised Person				
Signed:		Time:		Date:	

Working Party Control						
Detail of Persons who will be under the control of the PTW Holder being the recipient of this PTW as members of the Working Party. Persons signing to confirm that they understand the work to be completed.						
Name (Print name)	Date	Briefing Received	Time On	Signature	Time Off	Signature

Section 11 – Training and Authorisation

11.1 Training and Assessment

- a) All **Persons** who are required to work on **LV Systems Shall** be trained in the duties and procedures detailed in these **LV Safety Rules**. This will include all contractors undertaking work in accordance with these procedures on behalf of the **Company**.
- b) The training and authorisation process will be as follows:
 - Selection and nomination for the Authorisation category required
 - Satisfactory completion of the required Pre-authorisation training course(s) appropriate to the role to be undertaken within the previous 6 months
 - Undertake appropriate on-job training experience and demonstrate adequate knowledge, ability and competence for the required authorisation category
 - Complete a one day First Aid course within the previous 3 years
 - Evaluation by the **Assessing Officer** that the candidate has successfully completed the necessary training and is ready to be assessed by the **Authorising Engineer** for the required level of Authorisation
 - Assessment by the **Authorising Engineer** to ensure that the candidate possesses sufficient knowledge, training and experience necessary for the proposed level of authorisation
- c) Authorisation certificates will be valid for a period of three years. All **Persons** authorised under these **LV Safety Rules** will be required to undergo refresher training and re-assessment. Upon successful completion, a new certificate will be issued which will be valid for a further three-year period.

11.2 Authorisation

- a) The main duties and responsibilities of the **Assessing Officer** are:
 - Ensuring that prospective authorised **Persons** satisfactorily complete the required pre-authorisation training courses and on-job experience such that they possess a satisfactory level of knowledge, ability and competence for the required authorisation category
 - Put forward authorisation recommendations for consideration and evaluation to the **Authorising Engineer**
 - Providing any supporting information or guidance to the **Authorising Engineer** as part of the authorisation process
- b) The main duties and responsibilities of the **Authorising Engineer** are:
 - Assessment of prospective authorised **Persons** for suitability for appointment
 - Issue of Authorisation Certificates for authorised **Persons** under the **Company LV Safety Rules**
 - Suspend Authorisation of authorised **Persons** in the event of an accident or misconduct
- c) All **Persons** when issued with their certificate must check its wording to ensure they understand and agree with it.
- d) All **Persons** must ensure their certificate remains in good condition and they must carry it when they are working on **LV Systems**.
- e) The owner of an authorisation certificate must report its loss immediately to their **Authorising Engineer** and not undertake work on **LV Systems** until a new authorisation certificate has been issued, signed and is in their possession.

Section 11 – Training and Authorisation

- f) A record of all authorisation certificates will be maintained by the **Company**.

11.3 Suspension / Removal of Authorisation

The **Authorising Engineer** may suspend any issued Authorisation at any time. Authorisation **Shall** be immediately suspended under the following circumstances:

- A switching operation where switchgear fails with the ejection of material
- An erroneous operation whilst operating **Customer's** switchgear
- Non-compliance with these **LV** Safety Rules

Restoration of a suspended Authorisation **Shall** be the responsibility of the **Authorising Engineer**.

Section 12 — Arc Flash & PPE

Introduction

- 12.1.1 There is a legal requirement to identify the **Hazards** associated with all work tasks, assess the risks associated with those **Hazards** and identify and implement control measures to mitigate the risks they pose.
- 12.1.2 When considering work on or near to **Live electrical Systems**, it is normal to consider the risk of electrocution and **Live Conductor proximity Hazards** and how such risks may be eliminated or reduced. One important **Hazard** that can be overlooked but is present in electrical **Systems** is **Arc Flash** which can expose a person to significant burn injuries, UV radiation, explosions and potentially fatalities.
- 12.2 Arc Flash Risk Assessment
- 12.2.1 It is possible to undertake a quantitative assessment of the level of risk presented as a result of **Arc Flash** and then determine appropriate control measures to mitigate those risks.
- 12.2.2 NFPA70E (National Fire Protection Association) is a US internationally recognised standard which provides detailed guidance on the determination of **Arc Flash** risk and safety procedures including in the selection and use of PPE to mitigate risk. The term **Significant Arc Flash Risk** (Definition **D36**) where the **Incident Energy** (Definition **D20**) value at the point of work exceeds 1.2 calories/cm² and could result in a person receiving
- 12.2.3 partial thickness burns if not equipped with suitable **Arc Flash** PPE.
- 12.2.4 In order to complete such assessments, it is necessary to consider three variables:
- The prospective fault energy available under fault conditions at the point of work.
 - The time the upstream protective device will require to interrupt the fault current.
 - The distance away from a potential arc.
 - The electrode configuration within switchgear
- 12.2.5 This can be a complex task as it is often not possible to easily and accurately determine all the variables.
- 12.2.6 It should be noted that it will not be uncommon to find that the highest **Arc Flash** risk will occur in the downstream circuits of an electrical **System**. This is because the extended clearance time required by the circuit protective device will allow more energy to be released even though the fault level will be much lower than in the upstream part of the electrical **System**.
- 12.3 Arc Flash Risk Levels
- 12.3.1 The four levels of **Arc Flash** risk based on the American National Fire Protection Association (NFPA) standards document NFPA70E, are:
- Low Risk (Arc Flash)** is where the parts of the electrical **System** have a level of potential fault energy that is low and/or the fault clearance device's speed of interruption is able to significantly reduce the fault energy released such that Flame-Retardant overalls up to 4 cal/cm² will provide adequate protection to the torso and an arc rated face shield will protect the face.
 - Medium Risk (Arc Flash)** is where the parts of the electrical **System** have a fault level and protective device fault clearance times such that the fault energy released will be in excess of the protection afforded to a person by 4 cal/cm² 'Flame Retardant' overalls but within the protection band provided by 12 cal/cm² overalls. An arc rated face shield and

Section 12 – Arc Flash & PPE

stocking hood will protect the head and ear protection will be needed dependent upon the task.

- c) **High Risk (Arc Flash)** is where the parts of the electrical **System** have a fault level and protective device fault clearance times such that the fault energy released will be in excess of the protection afforded to a person by 8 cal/cm² overalls but within the protection band provided by 25 cal/cm² overalls. A switching hood will be required to protect the head along with appropriate ear protection.
- d) **Very High Risk (Arc Flash)** is where the parts of the electrical **System** have a fault level and protective device fault clearance times such that the fault energy released will be in excess of the protection afforded to a person by 25 cal/cm² overalls but within the protection band provided by 40 cal/cm² overalls. A switching hood with apron and impact resistant flame-retardant clothing will be required to protect the head along with appropriate ear protection.

- 12.3.2 NFPA 70E combines the levels of risk with associated tasks and identifies the corresponding level of **Arc Flash** PPE required for working on **Live LV Systems**.
- 12.3.3 It is essential that when undertaking work on, or in the proximity to, **Live LV Systems** an adequate Risk Assessment process is undertaken to ensure suitable and adequate control measures are in place to protect persons at work or others who may be affected by the work.
- 12.3.4 It is important that the hierarchy of control measures (eliminate, reduce, isolate, control, PPE and discipline) should always be applied when undertaking Risk Assessments with PPE being the last control measure to be considered. It is evident from the above, however, that PPE is an essential element in the protection of persons from **Arc Flash** risk and the Compliance Guide is a useful tool to ensure the correct level of PPE is always used.

Treatment for Electric Shock – Immediate and Speedy Action is Necessary

Free from Contact

Switch off the current immediately or send someone to do so. Do not attempt to remove a person from contact with high voltage unless suitable articles insulated for the system voltage are used for this purpose. When attempting to free a person from contact with low voltage use rubber gloves, boots, or mat, or insulated stick, but if these are not available use a loop of rope, cap or coat to drag the person free.

Whatever is used should be dry and non-conducting.

After Release

DO NOT WASTE TIME. If possible, lay the casualty on a firm, dry surface and gently open the casualty's airway and check for signs of breathing for up to 10 seconds by looking for chest movement, listening for sounds of breathing and feeling for breath on your cheek.

If there are no signs of breathing, commence with Cardiopulmonary Resuscitation. From a kneeling position by the side of the casualty, rock forward with arms held straight (keeping the fingers off the chest) so that the breastbone is pushed down 5-6cms. Release pressure. Compressions should be regular and smooth not jabbing or jerking, minimise pauses in chest compressions.

If the chest fails to rise during inflation, check that the jaw is lifted, the head tilted back and the mouth and throat are clear of obstructions.

Check for signs of circulation such as breathing, coughing or movement, continue until the casualty breathes spontaneously. Place the casualty in the recovery position.

Call for help throughout the process, share the duty of treatment with others competent to so if possible.

Once help arrives SEND FOR AN AMBULANCE and continue providing CPR if the patient has not regained a pulse and breathing.

Section 13 – First Aid

This page is intentionally blank

Section 14 — Non-Complex Work Guidelines

Non-Complex Work Activities

- 14.1 Where the work/testing activity is determined to be **Non-Complex Work** the work/testing may be carried out by a **Competent Person (LV)**.
- 14.2 **Non-Complex Work** will be typically an **LV** circuit or **Apparatus** which normally requires only one point of isolation from known voltage sources to ensure safety at the point-of-work and the working activity will normally be carried out by a **Competent Person (LV)** working alone.
- 14.3 **Competent Persons (LV)** undertaking **Non-Complex Work** will normally be responsible for undertaking their own pre-work Risk Assessments in accordance with **Company** policy and procedures.
- 14.4 The steps involved in ensuring that the **Apparatus** is **Dead** and safe to work on is outlined in Table 14 overleaf:

Section 14 – Non-Complex Work Guidelines

Table 14

Steps	Procedure
1. Identify and inform	Identify circuit to be worked on. Before any work or testing can begin, permission must be obtained from the person in charge of the area to be affected by the work or testing.
2. Confirmatory tests	Prior to any work being undertaken on the circuit, testing Shall be undertaken to confirm polarity and phase rotation, where appropriate.
3. Isolate and fix signs	<ul style="list-style-type: none"> a) Isolate from all potential sources of energy. b) Make Apparatus safe to work on or test. c) Fix Caution Notices at points-of-isolation and where practicable prevent unauthorised connection or operation by fixing Safety Locks. d) Where appropriate fix Danger Notices on Live equipment adjacent to the point-of-work or test.
4. Prove Dead	<ul style="list-style-type: none"> a) Ensure that the equipment to be worked on or tested is the equipment that has been Isolated. b) Where practicable, prove Dead with an Approved voltage test indicator at the points-of-isolation and/or at the location of the work or test.
5. Confirm Dead	Where it was not practicable in Step 4 to prove the equipment Dead , the Competent Person , using Approved tools and Personal Protective Equipment, is to confirm it Dead at the point-of-work or test as soon as Conductors have been made accessible to a voltage test indicator.
6. Pre-work testing	Prior to any work activities being undertaken, the Competent Person (LV) Shall determine and record the insulation resistance values and where appropriate the phase rotation and terminal markings of the Apparatus . Where the insulation resistance values are a cause for concern, work will not proceed until the reasons of the unacceptable values are identified and rectified.
7. Undertake the work or test	Undertake the work or test.
8. Post Work testing	Following the completion of the work the Competent Person (LV) Shall ensure that continuity and insulation resistance tests are completed and satisfactory, and where appropriate values recorded.
9. Restoration of supply	<ul style="list-style-type: none"> a) Remove safety precautions applied in section 3 above b) Energise the Apparatus c) When supplies are to be restored to three phase Apparatus confirmation tests for correct phase rotation will be undertaken.

Appendix 'A' – Customer Liaison Document format

		LV Customer Liaison Document			CLD No:					
1. Identification System, Equipment and Work										
Customer:										
Customer liaison person:					Phone No:					
Location:										
Equipment Identification: (State exactly the equipment that is to be worked on)										
Confirmation of the work to be done:										
2. Work Requiring HV Points of Isolation										
Will the above work require a point of isolation and earthing at HV?								Yes <input type="checkbox"/>		No <input type="checkbox"/>
If [Yes] who has operational control of this point of isolation?								Customer <input type="checkbox"/>		DNO <input type="checkbox"/>
How many points of HV isolation are required?								One		Two
3. LV point(s) of isolation under the operational control of Customer										
Does the Customer have a suitably competent Authorised Person to establish the LV point(s) of isolation								Yes <input type="checkbox"/>		No <input type="checkbox"/>
Does the Customer require LV point(s) of isolation to be undertaken by a Quartzelec LV Authorised Person?								Yes <input type="checkbox"/>		No <input type="checkbox"/>
If a Quartzelec LV Authorised Person is required to establish a LV point of isolation, does the customer have adequate network records of system arrangement and maintenance carried out?								Yes <input type="checkbox"/>		No <input type="checkbox"/>
4. LV Isolation Details										
Will the work require the Network Operator to isolate at the point of supply?								Yes <input type="checkbox"/>		No <input type="checkbox"/>
Will other points of isolation be required on the Customer's LV System to ensure that the Apparatus to be worked on is fully isolated?								Yes <input type="checkbox"/>		No <input type="checkbox"/>
Who will operate the Customer's isolation devices?								Customer <input type="checkbox"/>		Quartzelec <input type="checkbox"/>
If LV isolating devices are to be operated by a Quartzelec LV Authorised Person consent in writing must be granted (<i>by signing consent section 5</i>)								Yes <input type="checkbox"/>		No <input type="checkbox"/>
Responsibilities of Persons										
Customer's Safety Co-ordinator for this work is:					Mobile No:					
5. Customer's Consent for Quartzelec to Operate LV Switchgear (if required)										
I authorise Quartzelec to operate LV switchgear as may be necessary for the work to be carried out:										
Signed:					Name (block caps)					
Designation:					Date:				Time:	
6. Confirmation of Completion of Work and Equipment Is Ready for Re-Energisation										
I certify that the equipment identified in Section 1(b) can be re-energised and that all persons have been withdrawn and warned not to work on any equipment that may be affected by this re-energisation.										
Signed:					being the Quartzelec LV Authorised Person responsible for the work					
Time:					Date:					
7. Customer's Consent to Re-Energise										
I confirm that the equipment identified on this document can be brought back into service and that all persons who may be affected by it's restoration have been informed that it is about to be re-energised										
Signed:					Name (block caps)					
Designation:					Date:				Time:	

Appendix 'B' – Control Transfer Certificate format

Document No. CTCv4 X X X X X



Customer Electrical System - Control Transfer Certificate

PART (a) Customer Authorised Person Details

Company:..... Location:.....

Address:.....

Customer Authorised Person Print Name:.....

PART (b) Transfer of HV/LV* System Control from the Customer to Quartzelec Ltd

I being the above named Customer Authorised Person hereby declare that the Control of * PART / ALL of the Electrical System, at the above specified location and defined on the attached signed and dated System diagram, (Control boundary points specified in Part (c) of this Control Transfer Certificate), is now transferred to:

Print Name**Being the Control Person employed by Quartzelec Ltd.**

I also declare that there are no Safety Documents in issue on the transferred system and that I have informed all relevant employees of 'the Company' and other Contractors of this Control Transfer.

No access to, switching, operation, or work shall take place on the transferred System without the consent of the above named Quartzelec Ltd Control Person. At all stages the above named Quartzelec Ltd Control Person will liaise with the Control Person of other electrical systems that maybe affected.

Signed:.....Customer AP **Time** **Date**.....

Receipt

I hereby declare that I accept responsibility for the Control of the transferred Electrical System as Quartzelec Ltd Control Person

Signed:..... Quartzelec Ltd Control Person. **Time** :..... **Date:**.....

PART (c) Limits of Control Transfer

Substation/Switchboard*	Circuit	Item

PART (d) Transfer of HV / LV* Control from Quartzelec Ltd to the Customer

I hereby declare that I relinquish Control of the transferred Electrical System. All persons employed by Quartzelec Ltd have been informed and all Quartzelec Ltd Safety Documents have been cancelled.

Signed:.....Customer AP **Time** **Date**.....

*Attach modified System diagram duly signed and dated. (if there are any System alterations)

I hereby declare that I have resumed Control of the above System and this Control Transfer Certificate is cancelled (and have noted and understood any relevant alterations to the modified System diagram provided above)

SignedCustomer Authorised Person **Time** **Date**.....

* Delete as appropriate

Safety Rules Procedure 1 – Live LV Working

Contents	Page
1. Scope	58
2. Aims and Objectives	58
3. Standards.....	58
4. Category 'A' Flow Chart.....	62
5. Category 'A' Document	63
6. Category 'B' Flow Chart.....	64
7. Category 'B' Document	65
8. Live Work Certificate (Front Page).....	66
9. Live Work Certificate (Back Page).....	67

Safety Rules Procedure 1 – Live LV Working

1 Scope

- 1.1 This procedure sets out the procedure for working on or testing **Low Voltage** electrical equipment on **Customer's Low Voltage** networks. The policy enables **Live** working or testing to be completed in compliance with the Electricity at Work Regulations 1989, Regulation 14.

2 Aims and Objectives

- 2.1 The aim of this procedure is to enable electrical works or testing categorised as **Live** working under the Electricity at Work Regulations 1989 to be Risk Assessed and completed safely. The policy builds upon the guidance provided within the Quartzelec **LV** Safety Rules and provides enhanced levels of working procedures, Risk Assessment and approval.

3 Standards

- 3.1 When it is not reasonably practicable to isolate the **Low Voltage** equipment on which work or testing is to be carried out, work or testing may be carried out with the **Low Voltage** equipment **Live** under the following conditions:
- a) No work or testing **Shall** be carried out except in accordance with an **Approved** Safe System of Work.
 - b) The feasibility of work being carried out on **Live Low Voltage** equipment **Shall** be assessed by an **LV Authorised Person** who **Shall** specify the **Approved** procedure to be followed. The assessment of the work activity **Shall** include an evaluation of the risk from **Arc Flash** and the requirement to specify Personal Protective Equipment (PPE) requirements.
 - c) Risk of injury **Shall** be prevented by the combination of training, the use of an **Approved** Safe System of Work and the use of **Approved** tools and Personal Protective Equipment (PPE).
 - d) The work or **Testing Shall** only be carried out by an **LV Competent Person** who has been adequately trained and is experienced in the type of work or **Testing** to be undertaken.
 - e) When work is to be carried out on **Live Low Voltage** equipment, the **LV Competent Person** carrying out the work **Shall** be accompanied by an **Accompanying Safety Person** who has been trained to recognise **Danger** and can, if necessary, render assistance in the event of an emergency
 - f) For the avoidance of doubt, operational switching and linking on **Live Low Voltage Systems** can be carried out by an **Authorised Person** unaccompanied.
 - g) The **LV Competent Person Shall** understand the **Danger** which may arise during the work or **Testing**, and the precautions which need to be taken to prevent injury and can always recognise whether or not it is safe for the work or testing to be carried out.
 - h) **Persons** who are required to carry out work or **Testing** on **Live Low Voltage** equipment should first remove any metallic objects such as wristwatches, rings, wristlets, cufflinks, pendants, pens etc., which could cause short circuit if they accidentally come into contact with **Live** conductors.
- 3.2 Safety Rules Section 8.3 paragraph (f) exempts the following activities from the requirements of **SRP1 – Live Working**:
- Proving Dead
 - Functional Testing
 - Non-intrusive inspection

Providing the requirements specified in Section 8.3 can be met as illustrated in Fig.3.3

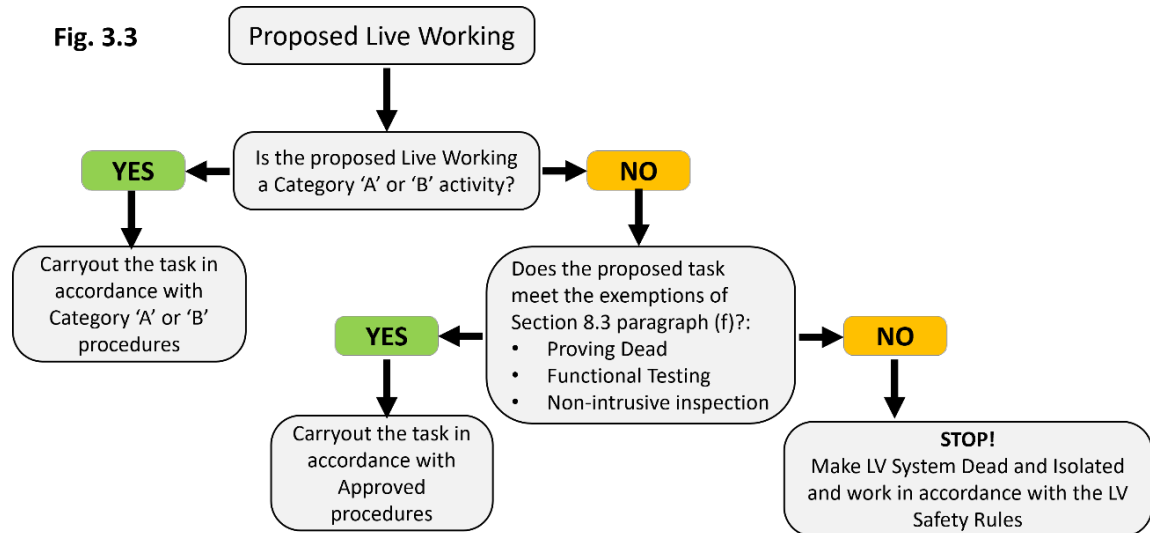

3.3 **Live Working** on LV equipment **Shall** be limited to the following two categories of work:

Category 'A'	<p>Testing on Distribution Boards which are Form 4 / IP2X compliant:</p> <ul style="list-style-type: none"> • Live Functional Testing, e.g. fixed wiring installation testing • Live Diagnostic Testing, e.g. testing Live equipment in order to establish operating conditions or values as part of a process to diagnose faults or sub-standard performance. <p>Notes:</p> <ol style="list-style-type: none"> 1. Testing on Non-compliant Form 4 / IP2X distribution boards under Live conditions is <u>NOT</u> permitted. 2. Category 'A' Risk Assessment form must be completed prior to any Testing being carried out.
Category 'B'	<p>Live Working activities:</p> <ul style="list-style-type: none"> • Adding or removing a Circuit or Switchboard component on Form 4 / IP2X compliant Distribution Boards • Removal / replacement of Neutral links for Circuit isolation purposes, i.e. to protect against the Danger of 'borrowed' neutrals • Live Battery work <p>Notes:</p> <ol style="list-style-type: none"> 1. Category 'B' Risk Assessment form must be completed prior to any work being carried out. 2. Where the Distribution Board is Form 4 / IP2X <u>Non-compliant</u>, the removal / replacement of Neutral links is the <u>ONLY</u> task which is permitted under a Live Work Certificate.

Safety Rules Procedure 1 – Live LV Working

- 3.5 Before work or **Testing** is commenced on **Live Low Voltage** equipment the following conditions **Shall** be met:
- a) The defined work activity **Shall** be identified as listed in 3.3 above. Once identified the appropriate process and form **Shall** be completed:
 - i) Category 'A' – Live Testing / Live Diagnostic Testing Assessment Form
 - ii) Category 'B' – 'Adding or Removing a Circuit or Switchboard Component' or Battery Work Assessment Form
 - b) If work which is defined as Category 'B' is to be completed, the Category 'B' Assessment Form must be completed by the **LV Authorised Person** responsible for sanctioning and controlling the proposed **Live Working** activity.
 - c) Category 'B' activities **Shall** be limited to the activities listed in the table in paragraph 3.3 above
 - d) Where the proposed **Live Working** task is on a distribution board which is to a non-Form 4/IP2X standard, the following limitations apply:
 - The removal and replacement of Neutral links for Circuit isolation purposes is the only task which can be undertaken
 - The **LV Authorised Person** responsible for the work **Shall** issue a **Live Work Certificate** to themselves, assume the role of **Person-in-Charge** and provide **Personal Supervision** for the duration of the work
 - Only **Competent Persons (LV)** who are trained and competent to undertake **Live Working Shall** be members of the **Working Party**
 - The **Person-in-Charge Shall** brief all members of the **Working Party** on the requirements of the Safe System of Work/RAMS prior to work commencing
 - An **Accompanying Safety Person Shall** be in attendance and once assigned to the role they **Shall** sign the relevant section on the back of the **Live Work Certificate**.
 - e) **Low Voltage** equipment **Shall** be visually inspected for soundness. **Low Voltage** equipment that exhibits corrosion, damage or is faulty **Shall** not be tested or worked on **Live**.
 - f) There **Shall** be adequate working space and a safe means of access and egress provided. The working space and the **Low Voltage** equipment on which work or **Testing** is to be carried out, **Shall** have adequate lighting.
 - g) All adjacent metal that is electrically bonded to earth or **Conductors** that are at a different potential to that on which work is to be carried out **Shall** be screened or shrouded with **Approved** insulating material to avoid **Danger**. The material used for screening **Shall** be of sufficient strength to withstand an accidental blow from a tool without tearing or otherwise ceasing to be effective.
- 3.6 When work is carried out on **Live Conductors** precautions **Shall** be taken to ensure that only one **Conductor** is exposed at any time.
- 3.7 Where necessary to prevent **Danger, Approved** safety equipment (insulated tools, insulating gloves, and insulating stands or mats, as appropriate), **Shall** be used and work **Shall** not proceed unless the necessary **Approved** safety equipment and suitable PPE has been provided. Rubber boots **Shall** not be used as an alternative to **Approved** insulating stands or mats.

Safety Rules Procedure 1 — Live LV Working

- 3.8 Where necessary to prevent **Danger, Approved** barriers, warning notices, etc., **Shall** be used to prevent access to the work or test area by other **Persons**.
- 3.9 **Testing** and running adjustments may be made with the **Low Voltage** equipment **Live** provided **Approved** safety equipment is used. If the testing or adjustment requires the removal of **Live** or metallic components, the requirements of paragraphs 3.1 – 3.5 above, **Shall** be met.
- 3.10 Where the testing or adjustment requires covers of **Live Low Voltage** equipment to be removed so that terminals or connections that are **Live**, or can be made **Live**, are exposed, then precautions **Shall** be taken to prevent unauthorised access to, or interference with, the **Live Low Voltage** equipment. Such precautions **Shall** include, where necessary, **Personal Supervision** and/or the erection of suitable barriers and the displaying of **Danger Notices**.

4 Category 'A' Flow Chart

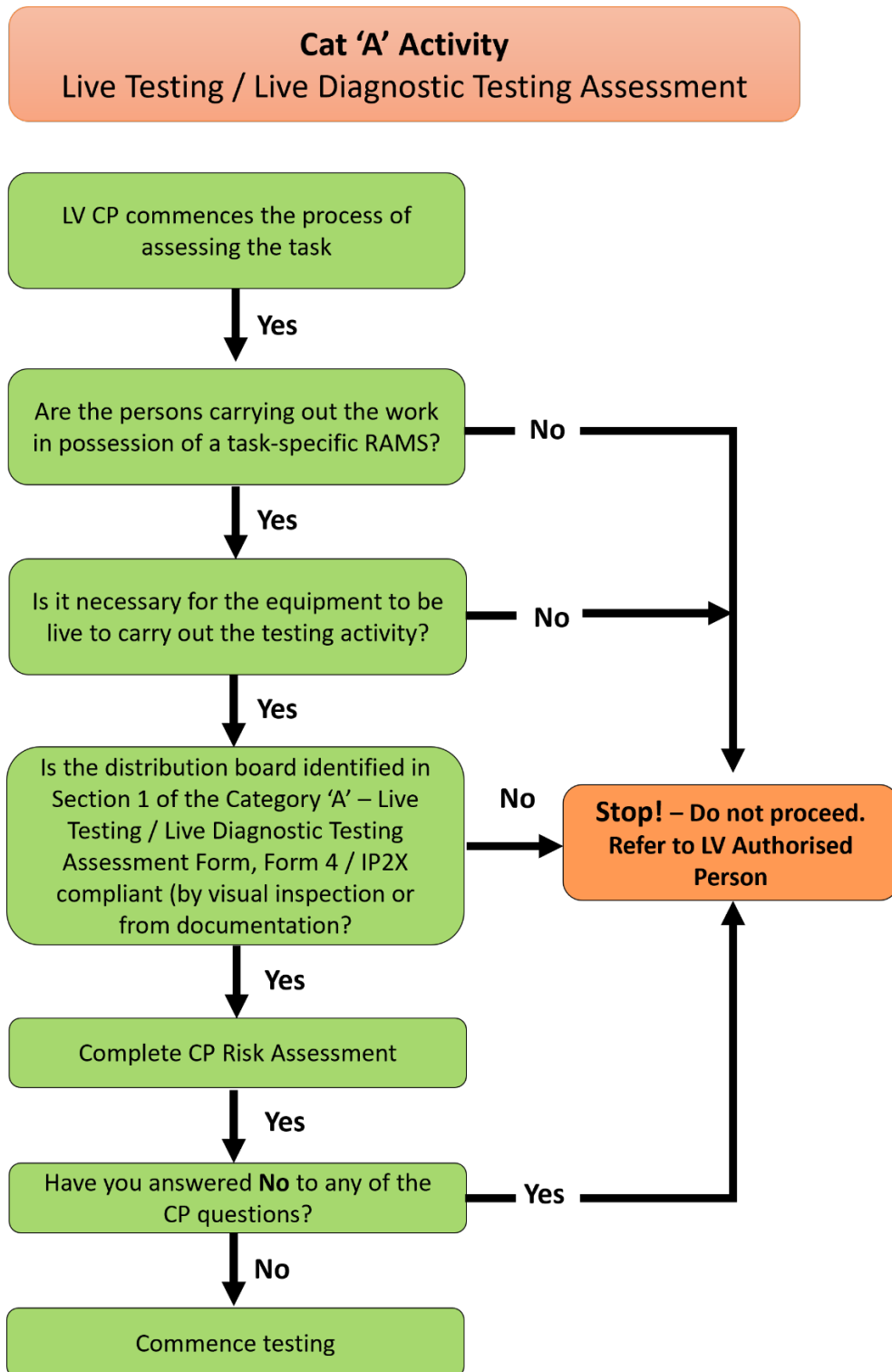

5 Category 'A' – Live Testing / Live Diagnostic Testing Form

	Category A – Live Testing / Live Diagnostic Testing Assessment Form	Form Number:
		Job Number:
Section 1: Equipment upon testing is to be carried out		
Location:	Equipment ID:	
Type of Equipment upon which testing will be carried out:	<input type="checkbox"/> Main LV Panel	<input type="checkbox"/> Sub-Distribution Board
Other:	<input type="checkbox"/> Other (Please Specify)	
If work forms part of a Complex Network (more than one source of electrical supply) then the LV Authorised Person must be informed and supervise the works/testing completing Section 2 and Section 3 below.		
Section 2: Persons responsible for the pre-work Risk Assessment and testing activities		
Person-in-Charge (Block Caps):	Employed by:	
Person assisting with testing activity (where required)	Employed by:	
2.1	Are the above-named persons in possession of Task-Specific RAMs and aware of the requirements and procedures set out by the Quartzelec LV Safety Rules?	Yes <input type="checkbox"/> No <input type="checkbox"/>
Note: If you have answered NO to the above question LIVE TESTING CAN NOT TAKE PLACE		
Section 3: Confirmation that live testing is necessary - Electricity at Work Regulations - Reg 14		
3.2	Is it necessary for the equipment to be live to carry out the testing activity?	Yes <input type="checkbox"/> No <input type="checkbox"/>
3.3	The reason live testing / live diagnostic is necessary: - (Tick) a. Disruption of services <input type="checkbox"/> b. Fault diagnosis not practical dead <input type="checkbox"/>	
3.2	Is the Distribution Board / Switchboard identified in Section 1 IP2X/XXB compliant (by visual inspection or reference to system documentation)?	Yes <input type="checkbox"/> No <input type="checkbox"/>
Signed:	Print name:	Date: Time:
Section 4: Competent Person's Risk Assessment (tick)		
		Yes No N/A
4.1	Are you a Competent Person authorised for live testing?	<input type="checkbox"/> <input type="checkbox"/> <input type="checkbox"/>
4.2	Have unnecessary personnel been removed from the test area?	<input type="checkbox"/> <input type="checkbox"/> <input type="checkbox"/>
4.3	Can you control the work area to achieve safe working?	<input type="checkbox"/> <input type="checkbox"/> <input type="checkbox"/>
4.4	Do you have all the information required to do the work?	<input type="checkbox"/> <input type="checkbox"/> <input type="checkbox"/>
4.5	Rubber gloves (Class '0' – 1000volt rating)	<input type="checkbox"/> <input type="checkbox"/> <input type="checkbox"/>
4.6	Approved insulated tools suitable for the proposed testing	<input type="checkbox"/> <input type="checkbox"/> <input type="checkbox"/>
4.7	Approved and calibrated GS38 compliant test instruments with fused leads	<input type="checkbox"/> <input type="checkbox"/> <input type="checkbox"/>
4.8	Approved insulated shrouding available (where required)	<input type="checkbox"/> <input type="checkbox"/> <input type="checkbox"/>
4.9	Barriers (where required)	<input type="checkbox"/> <input type="checkbox"/> <input type="checkbox"/>
4.10	Additional approved PPE appropriate for the testing activity	<input type="checkbox"/> <input type="checkbox"/> <input type="checkbox"/>
Note: If you have answered NO to any of the questions in sections 3 & 4 LIVE TESTING CAN NOT TAKE PLACE		
Section 5: Competent Person's confirmation safe to commence testing		
I have carried out the above checks and I am satisfied that it is safe to proceed. I confirm that I will carry out the tests in accordance with the approved RAMS for live testing. I also confirm that should I discover any breaches in the IP2X/IPXXB insulation, I will stop work and seek advice from the LV Authorised Person.		
Signed:	Print name:	Date: Time:
Section 6: Confirmation of testing completed		
I confirm that the testing is now complete, and that doors and access covers removed for testing have been closed or refitted.		
Signed:	Print name:	Date: Time:
Note: 1. If your tests indicate that a component needs to be removed or replaced, this exceeds the level of consent provided in this document as the activity will no longer be considered testing. Please refer to the electrical Safety Rules. 2. If completed by a Competent Person, this document must be returned to your supervisor		

6 Category 'B' Flow Chart

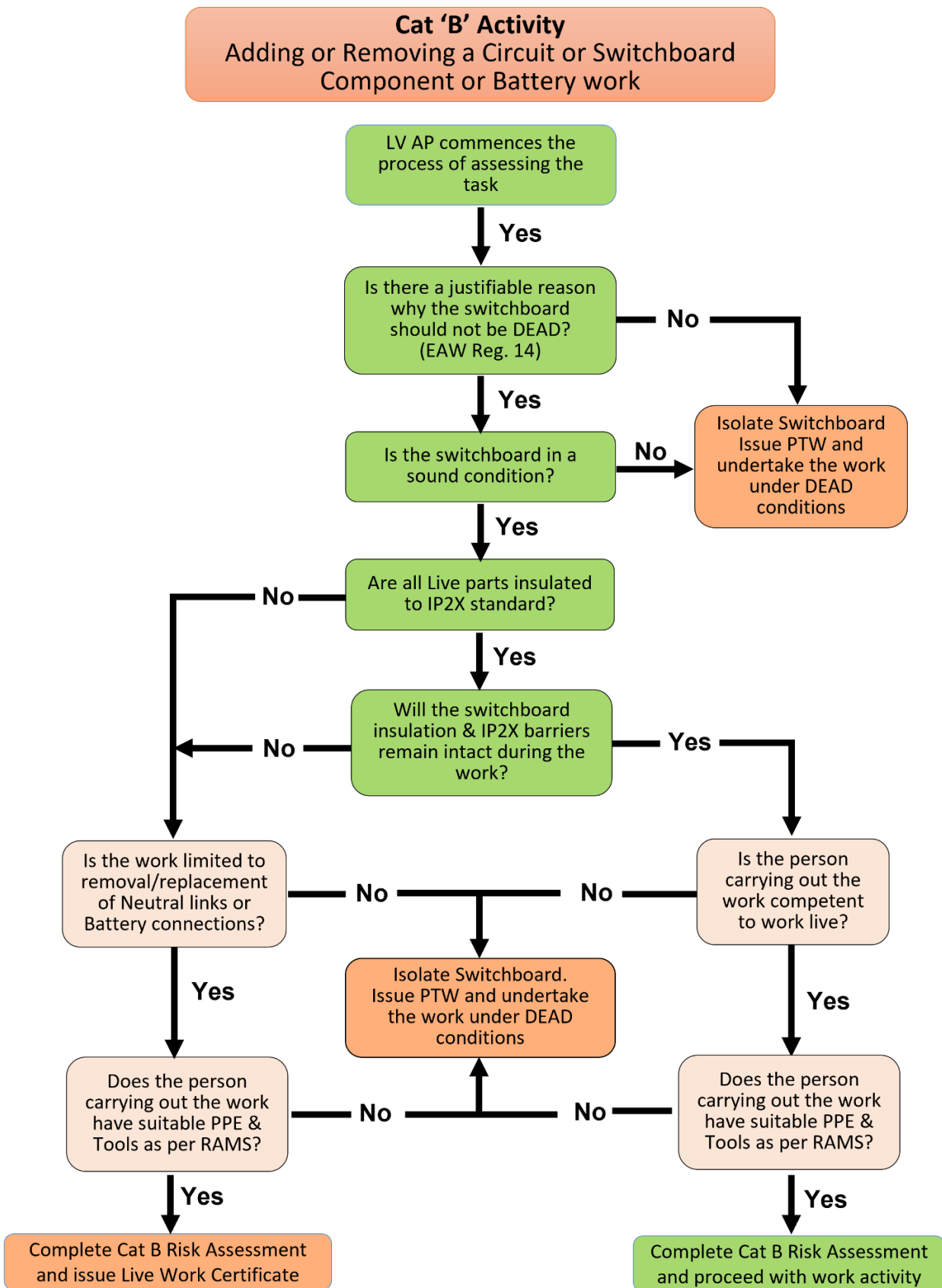

7 Category 'B' – Adding or Removing a Component Assessment Form

		Category B - Adding or Removing a Circuit or Switchboard Component		Form Number:		
				Job Number:		
This form must be completed by an LV Authorised Person <u>before</u> any Category 'B' activities are carried out on Low Voltage electrical equipment which will remain Live.						
Section 1: Equipment to be worked on						
Location:				Verified IP2X/XXB		
Equipment ID:						
				Yes	No	
Section 2: Nature of work to be carried out						
Connect additional circuit:			Disconnect/Remove existing circuit			
Add Switchboard component:			Remove switchboard component			
Other activity (describe):						
Section 2: IP2X/XXB Switchboard Assessment						
2.1	Can the work be carried out with the Switchboard Dead and fully isolated?				Yes	No
2.2	If the answer to above question is NO, are there justifiable reasons why the switchboard should not be fully isolated and worked on under Dead conditions?				Yes	No
2.3	Is the switchboard in a sound condition with all parts fully IPXXB and IP2X compliant?				Yes	No
2.4	Is there a risk that the proposed work activity could affect the integrity of the panel's insulation/separation with the risk of contact with Live conductors or short circuit?				Yes	No
NOTE: if any of the above questions has been answered NO, the work cannot commence until adequate safety measures have been applied						
Section 3: Non-IP2X/XXB Switchboard Assessment						
3.1	Can the work be carried out with the Switchboard Dead and fully isolated?				Yes	No
3.2	If the answer to above question is NO , are there justifiable reasons why the switchboard should not be fully isolated and worked on under Dead conditions?				Yes	No
3.3	If the answer to above question is YES , is your initial assessment that the work could be undertaken with the panel Live subject to the following requirements:					
	a) Can a suitable bespoke Safe System of Work (SSoW) be devised following a detailed Risk Assessment, to permit the work to be carried out safely?				Yes	No
	b) Can suitable insulated shrouding be applied under an approved SSoW which will achieve an IPXXB/IP2X standard of insulation/separation in order to prevent accidental contact with Live conductors or Short Circuit?				Yes	No
	c) Have the persons who will undertake the work the necessary level competence?				Yes	No
NOTE: If questions 3.2 or 3.3 have been answered NO, the work cannot commence unless the Switchboard is Dead, fully isolated and a PTW issued						
Section 4: Proposed actions arising from the above assessments						
4.1	Assessment indicates that the work cannot be undertaken under Live Conditions – panel must be made Dead and fully isolated from all sources of energy and a PTW issued				Yes	N/A
4.2	Assessment indicates that the work could be undertaken under Live Conditions – subject to: a) The preparation of a fully Risk Assessed SSoW b) Consent for the work (in writing) to proceed granted by the Authoring Engineer for Non-IP2X/XXB equipment. c) The application of insulated shrouding to achieve an IPXXB/IP2X standard of insulation/separation d) A Live Work Certificate issued and work carried out Personal Supervision of an LV Authorised Person				Yes	N/A
Section 5: LV Authorised Person completing this assessment						
Signed:		Print name:		Date:	Time:	

8 Live Work Certificate (Front Page)

	<h3 style="margin: 0;">Live Work Certificate</h3>	<table border="1" style="width: 100%; height: 30px;"> <tr> <td style="text-align: center;">LWC No.</td> </tr> </table>	LWC No.
LWC No.			
1. LV Electrical System identification and work/testing			
Category 'B' Live Working Activity Assessment Form No.			
Identification of LV Electrical System to be worked on:			
Work to be carried out:			
Reason for Live Working including why the work cannot be carried out under Dead and isolated conditions:			
2. Before work			
Are the following Safety provisions in place?			
(a) Accompanying Safety Person appointed	<input type="checkbox"/> Yes		
(b) Emergency response procedures known and understood	<input type="checkbox"/> Yes		
(c) Safety hook to remove person from an electrical source	<input type="checkbox"/> Yes		
(d) Insulated tools – appropriate for the task and in serviceable condition	<input type="checkbox"/> Yes		
(e) PPE – as required by the Safe System of Work	<input type="checkbox"/> Yes		
Approved Procedure to be complied with for the work/testing detailed in Section 1			
Safe System of Work / RAMS No:			
3. Issue:			
<p>I confirm that the appropriate Live Work Risk Assessment has been carried out and the safety measures required for the safe performance of the work and the appropriate tools and safety equipment is available at the point of work and the Safe System of Work / RAMS is appropriate for the work/testing detailed in Section 1.</p> <p>I understand the work/testing to be done and accept my responsibilities under this Live Work Certificate and confirm that I am authorised by the Quartzelec to receive and undertake work/testing under a Live Work Certificate. I confirm that the work/testing shall be undertaken in accordance with the requirements of the Quartzelec LV Electrical Safety Rules and the Safe System of Work detailed in Section 2.</p>			
Signed: being a Quartzelec LV Authorised Person			
Print Name: Time: Date:			
4. After Work			
CLOSURE: I confirm that all persons working under this Live Work Certificate have withdrawn from and warned not to carry out further work/testing on the LV Electrical System detailed in Section 1 and this Live Work Certificate is now cancelled.			
Signed: being the LV Authorised Person			
Print Name: Time: Date:			
Notes:			

Safety Rules Procedure 1 — Live LV Working

This page is intentionally blank

Safety Rules Procedure 2 — Arc Flash PPE Requirements

Contents	Page
1. Scope	70
2. Aims and Objectives	70
3. Arc Flash Terms.....	70
4. Determining an Incident Energy Value	71
5. Personal Protective Equipment (PPE) Requirements	72

Safety Rules Procedure 2 – Arc Flash PPE Requirements

1. Scope

- 1.1 This procedure sets out the procedure for selecting PPE for activities which are classified as **Live Working** on **Low Voltage** electrical equipment on **Customers Low Voltage** networks. The policy enables **Live** working or testing to be completed in compliance with the Electricity at Work Regulations 1989, Regulation 14.

2. Aims and Objectives

- 2.1 The aim of this procedure is to enable electrical works or **Testing** categorised as **Live Working** under the Electricity at Work Regulations 1989 to be Risk Assessed and completed safely. The policy builds upon the guidance provided within the Quartzelec **LV** Safety Rules and provides enhanced levels of working procedures, Risk Assessment and approval.

3. Arc Flash Terms

The following terms which appear in Section 2 (Definitions) of the **LV** Safety Rules are applicable in this **Safety Rule Procedure**:

Definition D4	ARC FLASH – An electrical breakdown of the resistance of air and/or other insulating medium resulting in an electric arc which can occur where there is sufficient voltage in an electrical System and a path to earth or adjacent phase Conductors , or lower voltage to sustain a continuous fault current. An Arc Flash will cause substantial damage, fire or injury.
Definition D20	INCIDENT ENERGY – The amount of thermal energy impressed on a surface, a certain distance from the source, generated during an electrical arc event, and is typically expressed in calories per square centimetre (cal/cm ²), or joules per square centimetre.
Definition D36	SIGNIFICANT ARC FLASH RISK – Where the Incident Energy value at the point of work exceeds 1.2 calories/cm ² and could result in a Person receiving at least superficial or partial thickness burns if not equipped with suitable Arc Flash PPE. (Reference source: NFPA70E [National Fire Protection Association] – A US internationally recognised standard).

Incident Energy represents the thermal energy which a person could be exposed to in the event of an **Arc Flash** event and can be used for the selection and use of suitable **Arc Flash** PPE. Where the **Incident Energy** value exceeds 1.2 calories/cm² this represents a **Significant Arc Flash Risk**.

Note: The **Incident Energy** value of 1.2 calories/cm², is taken from US standard NFPA70E – ‘Standard for Electrical Safety in the Workplace’, which is an internationally recognised electrical safety standard which provides detailed guidance with respect to the **Dangers** associated with **Arc Flash** and the selection and use of **Arc Flash** PPE.

Safety Rules Procedure 2 — Arc Flash PPE Requirements

4. Determining an Incident Energy Value

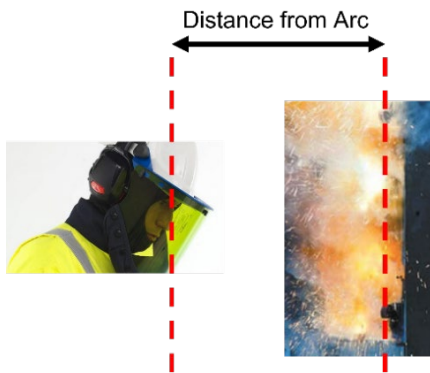

The **Incident Energy** value will depend on basically three things:

- The value of the Short Circuit current measured in amps (A)
- The distance from the **Arc Flash** event that the person's body measured in centimetres (cm)
- The duration (time in seconds) of exposure to the **Arc Flash** event – Normally the operating time of the up-stream protective device or the time for the person to withdraw (normally 2 seconds used for the person to withdraw).

The Short Circuit current value (I_{arc}) can be calculated using formulas taken from NFPA70E, which facilitates the calculation of the **Incident Energy** (IE_m) using the appropriate formula specified in NFPA70E dependent on the equipment to be worked on and the type of activity to be undertaken.

Alternatively, if the Short Circuit current (kA) the **Arc Flash** PPE category (1, 2, 3 or 4) can be determined by using the PPE selection tables contained in NFPA70E.

Typical working distances for working on **LV Systems** (600V and below as defined in NFPA70E) are:

- MCC and Panel Boards – 455mm (18 inches)
- Low Voltage Switchgear – 610mm (24 inches)

The determination of **Arc Flash** PPE requirements is set out in a separate **Arc Flash** PPE guide handbook.

Safety Rules Procedure 2 — Arc Flash PPE Requirements

5. Personal Protective Equipment (PPE) Requirements

- 5.1 **Persons** undertaking **Live Working** or switching activities **Shall** be provided with and use PPE that is suitable for the work activities to be undertaken. It is essential that the PPE conforms to the requirements of a fully Risk Assessed Safe System of Work. In selecting the PPE, due consideration must be given to the **Hazards** identified in the pre-work Risk Assessment and in particular the **Dangers** identified and quantified for the task to be undertaken.
- 5.2 The selection and use of suitable PPE for specific tasks **Shall** be as follows:

<p>Arc Flash Category 0 - Minimal Severity</p> <p>Appropriate and task relevant workwear, comprising non-melting fabrics and being free of metals.</p>
<p>Arc Flash Category 1 - Low Severity - Up to 4 Cal/cm²</p> <p><i>Clothing</i></p> <ul style="list-style-type: none"> • Arc Rated Long-Sleeved Collared Top with and Bottoms • Arc Rated Coveralls • Arc Rated Face Shield and Arc Rated Balaclava, or Arc Flash Hood <p><i>Equipment</i></p> <ul style="list-style-type: none"> • Hard Hat • Insulated Rubber Gloves (1000V Class 0) • Secondary Eye Protection • Hearing Protection • Leather Footwear
<p>Arc Flash Category 2 - Medium Severity - Up to 12 Cal/cm²</p> <p><i>Clothing</i></p> <ul style="list-style-type: none"> • Arc Rated Long-Sleeved Collared Top with and Bottoms • Arc Rated Coveralls • Arc Rated Face Shield and Arc Rated Balaclava, or Arc Flash Hood <p><i>Equipment</i></p> <ul style="list-style-type: none"> • Hard Hat • Insulated Rubber Gloves (1000V Class 0) • Secondary Eye Protection • Hearing Protection • Leather Footwear
<p>Arc Flash Category 3 - High Severity - Up to 25 Cal/cm²</p> <p><i>Clothing</i></p> <ul style="list-style-type: none"> • Arc Rated Long-Sleeved Collared Top with and Bottoms • Arc Rated Coveralls • Arc Rated Balaclava and Arc Flash Hood • Arc Rated Jacket <p><i>Equipment</i></p> <ul style="list-style-type: none"> • Hard Hat with Arc Rated Liner • Insulated Rubber Gloves (1000V Class 0) • Secondary Eye Protection • Hearing Protection • Leather Footwear

Safety Rules Procedure 2 – Arc Flash PPE Requirements

<p>Arc Flash Category 4 - Very High and Unacceptable Severity - Greater than 25 Cal/cm²</p> <p>Whilst PPE exists to mitigate the effects of Arc Flashes greater than 25 Cal/cm², these rules would deem them appropriate only if they do not impede on the safety and comfort of the User or impinge on their range of motion to complete the anticipated task. Should either or both of these issues persist, then no PPE will be deemed suitable and therefore the task must be completed through different means.</p>
<p>Notes:</p>
<ol style="list-style-type: none"> 1 Only PPE and equipment approved by the Company should be used. <ol style="list-style-type: none"> a. PPE Clothing and Equipment shall comply with CE and UKCA markings as required, and carry markings to indicate its compliance with the following standards so far as it is intended for a task: <ol style="list-style-type: none"> i. IEC 61842 ii. EN ISO 11611 iii. EN ISO 11612 iv. BS EN 1149-5 v. EN 13034 vi. EN ISO 20471 2 PPE Shall demonstrate and be inscribed with the ELIM Value for withstanding an Arc Flash Incident Energy Value, where an ELIM value is not provided, then APTV value of equal or greater protection shall be sufficient. 3 Where gloves are subject to mechanical damage e.g. cuts, abrasion etc., consideration should be given to the use of Approved additional Leather protection gloves.

5.3 The above PPE requirements **Shall** be considered as the minimum requirements. Where a pre-work Risk Assessment or specific Safe System of Work specifies a higher specification of PPE than that listed above, it **Shall** be used.

Document Control

Edition / Issue Version	Issue Date	Brief Description of Change

Approved: Date:

Ashley Knight - Safety Manager